

Bringing you sewing inspiration for 20 years

www.sewingworldmagazine.com

# sewing WORLD

June 2015

**100**  
packed  
pages for  
you to enjoy

Perfect for  
summer excursions

Fresh  
summer  
florals

Fabulous projects for  
you and your home

Holiday essential



Here comes  
the sun!

Fashionable  
& Floaty

TEMPLATE Issue 232 £5.99



SEWING WORLD JUNE 2015

www.sewingworldmagazine.com

Carry  
on  
your  
passion.



Designed for women and men, our technically advanced, unique formula contains **Marine Bionovex® Oil** (from New Zealand Green Lipped Mussels) and **Hyaluronic Acid** (a key component of synovial fluid, cartilage, tendons and ligaments).

**Find them in the vitamins and supplements aisle.**

Regenovex Capsules are a food supplement, which should not be used as a substitute for a varied balanced diet and healthy lifestyle.



**REGENOVEX®**

**3 for 2 on Regenovex**

Shop online at [boots.com](https://www.boots.com)



let's feel good

Cheapest free. See instore for details. Available at most Boots stores. Subject to availability.

# Hello



Emma Horrocks  
sw@traplet.com

Welcome to our June issue and hopefully the arrival of summer; warmer weather, longer daylight hours and if we are lucky some free time and days out. This issue is packed with lots of projects that characterise the relaxing spirit of summer. Take our empire line [summer sundress](#) – perfect for relaxing sunny days in the garden, a weekend at the beach or dining al fresco with friends. This month's cover star – the fresh and floral [shoulder bag](#) – would be a great accessory for day trips and looks great with jeans and casual clothes.



We have some lovely makes for your home too – the [criss-cross table runner set](#) is easy to make and a great introduction to quilting. The [scratchin' chicken bag recycler](#) has fun with free-machine embroidery and appliqué and the bright [sundial cushion](#) will bring a ray of sunshine to your lounge.

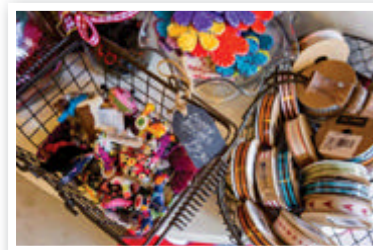

We have our usual mix of techniques tutorials to help you master and hone those sewing skills. This month Susan takes us through inserting zips in her specialist [bag making series](#) and Wendy's masterclass looks at [decorative edgings](#) to add those finishing touches to your projects. Plus we have all of your regulars and favourites.

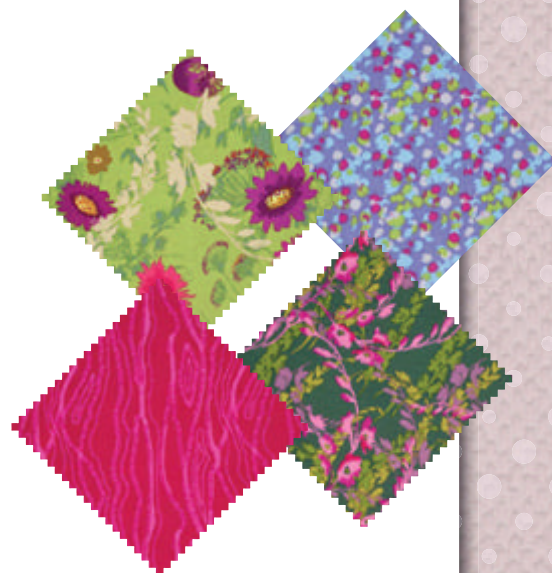

As this is my first issue as editor, I must say thank you to everyone who helps put Sewing World together, and for the very warm welcome you have given me. I am looking forward to new and exciting sewing times ahead!

*Emma x*



PS For those of you who love your iPad and Smartphones, Sewing World magazine is available to download as an app from apps stores or for home computers, click on [www.pocketmags.com](http://www.pocketmags.com). For digital readers, the patterns for all the makes are free to download from the Sewing World website.

Don't forget to visit us on Facebook and visit Sewing World's website ([www.sewingworldmagazine.com](http://www.sewingworldmagazine.com)).



# Contents

June 2015



## Regulars

- 3 Hello
- 6 Go Shopping!
- 10 News
- 12 The Fabric Stash
- 74 Creative Clippings
- 82 Course Roundup
- 84 Pattern Roundup
- 88 Bookshelf
- 90 Ready, Get Set Sew!
- 97 Coming Next Month
- 98 The Final Thread

## Techniques & features

- 56 We Meet Janet Clare
- 59 Competition
- 60 Fabric Showcase – Summer Florals
- 62 Masterclass – Decorative Edgings
- 68 We Visit CallyCo
- 70 Brilliant Bagmaking – adding zips
- 78 Re-fashion! Collars



# Projects

## 16 Summer-time

Modern shoulder bag

## 22 Here comes the sun

Empire line sundress



## 27 Sundial Cushion

Easy appliqué circles



## 32 Cosmetic Purse

Using Vilene Lamifix

## 36 Fun in the sun!

Girls sun-top and skirt



## 40 Funky Key Fob

Colourful key holder



## 44 Criss-cross Table Runner Set

Quilted runner and coasters

## 47 Bear Cushion

Animal friend cushion



## 50 Scratchin' Chicken

Appliqué and embroidered bag recycler



## 52 Home from Home

Campervan picture



Digital readers – free downloadable patterns are available at [www.sewingworldmagazine.com](http://www.sewingworldmagazine.com)



22



### Editor

Emma Horrocks

### Editorial Assistant

Aimee Beard

### Contributors

Ruth Lazarus, Diane Allerston, Julia Claridge, Lou Orth, Debbie Von Grabler-Crozier, Susan Dunlop, Laura Strutt, Claire Muir, Chris Gray, Angela Venn, Wendy Ward and Kerry Green.

### Managing Director

Tony Stephenson

### Operations Director

Tom Stephenson

### Design and Production Manager

Nick Powell

### Magazine Design and layout

Katy Evans

### Styling & Photography

Julie Briggs, Aimee Beard and Tom Sochacki

### Advertising & Trade Sales

Michelle Lazenby tel: 01684 588534

Email: michelle.lazenby@traplet.com

### Advertising Copy Control

Cindi Griffiths tel: 01684 588517

email: adcopy@traplet.com

### Printer

Warners plc

### Newsstand Distribution

Seymour Distribution Ltd. (020 7429 4000)

### Craft Trade Distribution

Traplet Publications Limited (01684 588568)

### US Distribution

Traplet Distribution USA Ltd.,

816 N. Country Fair Drive, Suite 5

Champaign, Illinois 61821

Tel: 217-355-2970 Fax: 217-954-0472

email: usa@traplet.com

### Australian Distribution

Traplet Publications and Hobbies,

P.O. Box 501, Engadine, NSW 2233, Australia.

Tel: (02) 9520 0933 Fax: (02) 9520 0032

email: sales@traplet.com.au

### South African Distribution

Traplet Publications South Africa (PTY) Ltd.

P.O. Box 1067, Oudtshoorn, 6620, South Africa

Tel/Fax: +27 44 272 5978

email: southafrica@traplet.com

### Published by

Traplet Publications, Traplet House, Willow End Park

Blackmore Park Rd, Malvern WR13 6NN

Tel: 01684 588599, Fax: 01684 578558

email: customerservice@traplet.com

### Subscriptions

1 Year subscription prices:

UK £71.88 Worldwide £98.28

Europe £94.68

USA & Canada US \$159.24

2 Years subscription prices:

UK £143.76 Worldwide £196.56

Europe £189.36

USA & Canada US \$318.48

### Back Issues

UK £4.95/US \$11.99

Customer Service: 01684

588500

Order Hotline: 01684 588599

Online Ordering: [www.trapletshop.com](http://www.trapletshop.com)



This publication is printed by Warners 01778 395111



This magazine is sold subject to the following conditions: that it shall not without written consent of the publishers be lent, resold or otherwise disposed of by way of trade in excess of the recommended maximum retail price.

All rights strictly reserved. No part of this publication may be reproduced in any way without the prior agreement of the publisher. All letters must be accompanied by the sender's full name and address. The publisher cannot accept responsibility for unsolicited correspondence nor some of the opinions expressed. All material and artwork originated by Traplet Publications Ltd., photographs, drawings, plans used in this magazine become the publishers copyright under Copyright law. Some photographs may have been digitally re-mastered. The Company reserves the right to suspend or refuse any advertisements without giving reasons. Whilst every care is taken to avoid mistakes, Traplet Publications Ltd. cannot be liable in any way for errors or omissions. Nor can the Publisher accept any responsibility for the bona fides of advertisers.

© Traplet Publications Limited 2015 ISSN 1352-013X

44



## 9 Savile Row

9 Savile Row is an exclusive collection of tailoring accessories and haberdashery tools from Merchant & Mills that has been created in celebration of the Alexander McQueen: Savage Beauty exhibition at the V&A. The collection is named after the address of Alexander McQueen's flagship menswear store, just a short distance from where the visionary designer first trained and worked as an apprentice tailor. Merchant & Mills was founded in 2010, its mission to bring the skill and craftsmanship of pattern cutting to the wider dressmaking public. Beautifully designed and elegantly packaged, 9 Savile Row products are available exclusively from the V&A Shop and include pins, needles, tailors chalk, scissors and more.



Prices start from £3.75

Available exclusively from the V&A Shop, visit [www.vandashop.com](http://www.vandashop.com)

# GO Shopping!



## Polka Dot Knickers Kit from The Makery

Successful, Bath based haberdashery and online store The Makery have launched a new gorgeous range of kits – and in their own words 'We're so proud of our brand new range of kits!' And so they should be! The Polka Dot Knickers Craft Kit shown includes everything you need to make a pair of knickers – pattern (for small, medium and large sizes), instructions, lovely 100% cotton fabric, cotton thread on a wooden spool, a needle, some super knicker elastic, pretty crocheted cherries and yellow ribbon to adorn your pants with. The packaging is beautiful; really robust, with sumptuous gold foil lettering. What a treat for yourself or a friend. Other kits in the range include Make a Lampshade, Clasp Purse and Rosette Brooch kit.



The Polka Dot Knickers kit is priced at £14.95



The New range of Makery kits available from The Makery, [www.themakery.co.uk](http://www.themakery.co.uk) or at John Lewis, [www.johnlewis.com](http://www.johnlewis.com)

## Pretty Covered Buttons

These pretty floral fabric covered buttons from Groves are just the thing to add a touch of Spring/Summer to sewing projects. Perfect for embellishing your home sewn garments and home accessories, they can replace buttons on a cardigan or jacket to add a little detail, refresh and up-cycle. Beautifully presented in hessian packs of 12 buttons, all 15mm diameter and available in a choice of 6 fabric prints – Red Floral, Denim Blue, Purple Floral, Green Floral, Blue Floral & Yellow Floral.



**Covered buttons RRP £3.20 per pack**

Groves decorative products are available nationwide from sewing and craft shops.  
For stockist information email – [groves@stockistenquiries.co.uk](mailto:groves@stockistenquiries.co.uk)

## Zazzle Your Fabric!

Zazzle are a company that specialise in personalising... well, almost anything that you can think of – mugs, stationery, t-shirts, cushions, bags, badges, even skateboards! All printed on high quality and designed products. Their new venture is personalised fabric and ribbon printing. The website takes you step-by-step through the seven different fabrics options from cotton twill to combed cotton and natural linen. There are a range of designs that you can use or add your own stamp to or design your own from scratch. Printed on demand with eco-friendly inks and available in fat quarters or by the yard. We especially love the ribbons!



**Prices start from £9.50 for a 2 yard spool of customised ribbon or £19.95 for a yard of Combed Cotton fabric (+P&P)**



Visit the Zazzle website [www.zazzle.co.uk](http://www.zazzle.co.uk) and with lots of project ideas on their blog too – visit, [blog.zazzle.com](http://blog.zazzle.com)

## Pompoms Galore!

Multipom is a new pompom maker that has been designed in Suffolk and has revolutionised pompom making! The new Multipom is the only pompom maker on the market which can make more than one pompom at a time; in fact it can make up to 20 identical pompoms quickly and easily in all sizes from 1 – 12cm diameter. The pompom making kits are suitable for adults and children and even groups, are simple to use and they have wide ranging applications within furnishings, braids, trimmings, fashion, decorations and crafts. They make a great edging for cushions and we love the natural bedspread pictured here.

**Multipom Pompom maker is priced at £12.99 and Starter kit prices start at £15.99 (+P&P)**

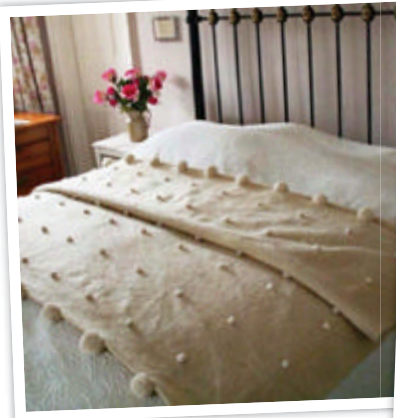

Available to buy from the Multipom website,  
[www.multipom.com](http://www.multipom.com) or  
 email [mail@multipom.com](mailto:mail@multipom.com)

## New Bernina 350 Special Edition

Market-leading Swiss sewing, quilting and embroidery machine manufacturer Bernina has launched two special limited edition versions of its 350PE model in the UK incorporating specially designed faceplates by leading designers Ricky Tims and Tula Pink. These new designs are the result of Bernina's 'Faceplate Face-off' competition that allowed Facebook fans to choose two designs to be featured on the new 350 Special Edition models. The Bernina 3 Series line of machines is ideal for both beginners and more experienced sewers. It is an outstanding choice for everyday mending jobs and alterations, as well as creative sewing and quilting. The B350SE comes equipped with six full shank presser feet, a slide-on extension table to quickly increase the work area, and the Free Hand System which is a knee-operated lever that raises the presser foot, lowers the feed dog and releases the thread tension at the same time. With 115 stitches, a maximum sewing speed of 900 stitches per minute, it also has a direct-selection function with a bright LCD screen that allows users to switch quickly between the 20 utility stitches, 52 decorative stitches and 11 quilting stitches. And of course, you are assured of the high quality product that Bernina offers.



Bernina products are sold in the UK through a network of specialist, fully trained independent dealerships. To learn more and to find a dealer, visit [www.bernina.com/en-gb](http://www.bernina.com/en-gb) or call 020 7549 7849



THE FUTURE OF SEWING IS NOW AT

# David Drummond

CELEBRATING OVER 40 YEARS ESTABLISHED 1974



PHONE DAVID WHO IS ALWAYS ON THE BALL TO GIVE THE BEST ADVICE AND THE MOST COMPETITIVE PRICE IN THE UK



PLEASE PHONE DAVID FOR AN EXCEPTIONAL TRADE-IN OFFER

## JANOME MEMORY CRAFT 8900QCP

The Memory Craft 8900QCP is the pinnacle of our range of long-arm models.

Fully computerised with freearm  
Extra long 280mm (11") arm space  
975 built-in stitches including alphabets  
270 stitches, 61 block patterns plus 3 fonts  
9mm stitch width  
Sews up to 1,000 s.p.m.  
11 Styles of auto 1-step buttonholes  
Up/down flip design

Favourite stitch  
Pattern elongation - up to 5 times  
Information screen with jog dial selection  
Jam proof drop-in bobbin  
Variable stitch width and length  
Automatic tension  
Auto needle threader  
Auto thread cutter

Remote thread cutter port  
Easy change needle plate  
Built-in AcuFeed system  
Superior 7 piece feed dog for precise feeding  
Drop feed for freehand work  
Maximum speed controller  
One touch slow function  
Needle up / down facility



DAVID personally guarantees that if you have a problem or simply require a service for the lifetime of your machine, he will arrange FREE COLLECTION/DELIVERY, to and from your door for any machine bought from him. There will be no charge for repairs if machine is under warranty.



stockists of;



77/81 Haymarket Terrace, Edinburgh. EH12 5HD  
(200 yds from Haymarket Station)

OPEN 6 DAYS A WEEK  
Monday to Saturday 9am - 5:30pm

FREE 24 HOUR UK DELIVERY  
0131 539 7766



# NEWS NEWS NEWS

## Get the latest

What's going on in the world of sewing...

### WI Centennial Fair



The WI Centennial Fair will be the peak of the WI's 2015 centenary celebrations. Taking place in the picturesque spa town of Harrogate, North Yorkshire, from 3th – 6th September 2015, the fair will offer a great day out and an unmissable opportunity to sample fabulous food and drink, try your hand at over 150 seminars and workshops and of course lots of shopping. For craft and sewing lovers – there will be an opportunity to participate in craft workshops, visit the Make it Yourself theatre and the Etsy Business School. Etsy staff will be running classes on how to set up an Etsy shop and how to get the most out of social media, whilst sellers and local WI branches will be talking about what makes for a successful Etsy business – all the tools you need to start making money from your hobby.

For more information on the show visit [www.thewishow.com](http://www.thewishow.com).

### Colourshott Bloghop

How much fun can you have with a stack of Colourshott 10" squares? Quite a lot, it seems!

Oakshott who are known for their high quality shot cotton fabrics, collaborated with their great friend and designer, Lynne Goldsworthy of Lily's Quilts ([lilysquilts.blogspot.co.uk](http://lilysquilts.blogspot.co.uk)) and eight wonderful quilter/

bloggers to work their fabric magic. As a result, there are eight stunning and highly individual projects to fuel your inspiration which have been collated together into a free to download eZine. For each project, the designers show you how it's done and share their tutorials via a link to their own website. The new Colourshott 31-57 range continues the grand tradition of shot cottons, building on the success of the original collection that launched the brand. The 10" Square Pack is a tempting bundle of 27 colourways which combine a base colour warp with a rainbow of weft threads – the trademark Oakshott colour intensity and 'shot' effect. 100% mercerised shot cottons, they're suitable for all quilting and general sewing projects. The New Colourshotts shimmer and shine together, allowing you to mix, match and tone with complete confidence.

To download the free Colourshott eZine visit [www.oakshottfabrics.com](http://www.oakshottfabrics.com).



### New Designers 2015

New Designers presents an unmissable opportunity to buy new products, get inspired by fresh ideas and see new design talent. Every year over 3,000 of the most promising graduate talents from Britain's leading design courses exhibit their design work and ideas at the show. New Designers features everything from textiles and jewellery to product design and illustration. Nowhere else is it possible to see such innovation and creativity and the content is completely new every year. Held over two weeks at the Business Design Centre, Islington, London. The textile and fashion exhibitors on display from 24th – 27th June 2015. For more information visit [www.newdesigners.com](http://www.newdesigners.com).

# NEWS NEWS NEWS

## Significant Seams Craftivism

A local community hub and craftivist organisation based in Walthamstow, East London – Significant Seams have been busy with their fifth community quilt themed on the Changing Role of Women. The quilt will be displayed at St Mary's Church in Walthamstow Village as part of a wider art exhibition for the E17 Art Trail and representing the community of Walthamstow but telling a global story. Participants in Significant Seams' weekly ESL Sew & Tell course, students from the area's secondary schools and its Neighbourly Knit & Stitch sessions have made patches from recycled cottons and upholstery fabrics that respond to questions like, 'How is your life different from your mother's?' 'What do you think prevents women from achieving their dreams or ambitions?' 'What has surprised you about what you have achieved?' Reflecting the diversity of the borough, the quilt uses a variety of different textile techniques. The Community Quilt will be on display during the E17 Art Trail 30th May – 14th June 2015.

For more information visit [www.significantseams.org.uk](http://www.significantseams.org.uk).



## Readers' Makes of the Month!

Our Readers' Makes of the Month winner for June is **Ali Lisle** – who wins a box of Mettler Poly Sheen threads – 100% Trilobal Polyester threads, perfect for all your sewing needs!



Ali says – 'I am a sewing machine newbie! Having not touched a needle for almost 30 years (the last time being at primary school), my wonderful husband bought me a sewing machine for Christmas (at my request, I hasten to add) and shortly after I subscribed to your exceptionally useful magazine. I now have completed projects from my first few months, including a couple from Sewing World and I wanted to share with you my personal achievements! They're not perfect by any stretch, but I enjoyed every minute – even those minutes spent unpicking my stitches.

The bags were inspired by the Petite Street article and I chose some other Dashwood Studio fabrics that I thought might work well. I think the Wildwood fabrics in particular look great.

Thank you for bringing inspiration and explaining it all so well. I look forward to each month when my new Sewing World mag drops on the mat and my next challenge awaits...'



Thank you Ali – what a superb collection of bags you now have. Keep on sewing – there are lots more projects just waiting to be made!

Send me some pictures of YOUR makes and you too could be featured in the Makes of the Month column and win a lovely prize!

**PRIZES TO BE WON!**

(Write to Sewing World at Traplet Publications, Traplet House, Willow End Park, Blackmore Park Rd, Malvern WR13 6NN or email: [sw@traplet.com](mailto:sw@traplet.com).

Visit our Facebook page [www.facebook.com/sewingworldmagazine](http://www.facebook.com/sewingworldmagazine))

# The Fabric Stash

## Designer Details:

All of Nel Whatmore's fabric collections are inspired, one way or another, by her painting style. Sketch Book is a collection that looks at the simple beauty and importance of line, both in patterns and art. Nel says 'All the things I think about while painting, I now think about when designing collections and quilts. It's like having another palette of tricks to play with! I hope you enjoy using and exploring Sketch Book!'

# Sketchbook by Nel Whatmore for Free Spirit Fabrics

## The Collection:

Sketchbook showcases vivid and rich jewel coloured designs, some fluid painterly florals, others more abstract and tonal. A great inclusion to any stash of summer fabrics!

## Stockist Details:

Sketchbook is available from a wide range of stockists. To find your local retailer, see handy tutorials and download free projects visit [www.makeitcoats.com](http://www.makeitcoats.com)

# Unleash your creativity with the Innov-is XV



## Being great just got easier

With the new Innov-is XV everything's easier, faster and more intuitive than ever.

Create large projects easily with our largest embroidery area. Convert scanned images to embroidery data in just a few seconds without any extra software or a computer. Add stippling embroidery where you like.

This is the machine on which you'll perfect your skills and turn your dreams into reality.

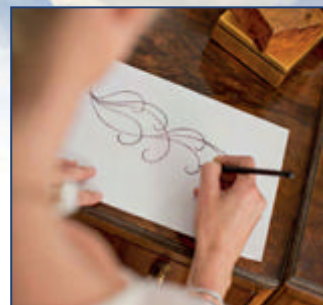

Draw it



Scan it

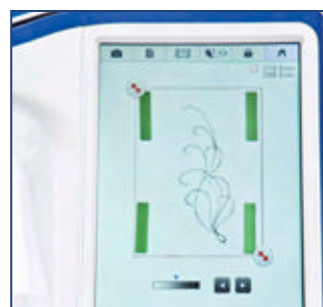

Convert it



Stitch it



**JUNE**

*makes*



# Summer-time Shoulder Bag

DESIGNED BY Susan Dunlop of SusieDDesigns

Use fresh floral fabrics to make this modern bag that will compliment your summer outfits perfectly. Piped binding is used on the flap and the main bag body for added texture and stability.





## Materials

- Fabrics 1, 2, and 3 are from Suffolk Garden, by Brie Harrison for Dashwood Studio
- 30cm fabric 1 – cotton print, Dandelions in Ecru
- 30cm fabric 2 – cotton print, Daisy Spot in Mint
- 30cm fabric 3 – cotton print, Fern in Yellow
- 30cm lining fabric – cotton solid, Moda Bella Solids in Yellow by Moda Fabrics
- 1m medium weight, woven fusible interfacing
- 25cm low loft fusible fleece
- 2m of 25mm bias binding
- 2m of 2.5mm piping cord
- 15mm riveted press snap and fixing tool
- Zip presser foot

## Good To Know

- Fabric width used 112cm throughout.
- R/S – right side, W/S – wrong side.
- RST – right side together WST – wrong side together.
- Seam allowances are included in the cutting sizes.
- Use 1cm seam allowance throughout, unless stated otherwise.
- Finished size is 26cm x 30cm x 6cm.

## To Cut

### Fabric 1:

- Cut 2 28cm x 30cm, main body

### Fabric 2:

- Cut 2 16cm x 30cm, centre panel
- Cut 1 18cm x 22cm, flap closure

### Fabric 3:

- Cut 4 8cm x 28cm, top panels
- Cut 1 10cm x 90cm, shoulder strap

### Lining fabric:

- Cut 1 18cm x 22cm, flap closure lining
- Cut 2 28cm x 30cm, main body lining

### Fusible interfacing:

- Cut 4 28cm x 30cm, main body outer/lining
- Cut 2 14cm x 30cm, centre panel
- Cut 4 8cm x 28cm, top panels
- Cut 2 18cm x 22cm, flap closure
- Cut 1 5cm x 90cm, shoulder strap

### Fusible fleece:

- Cut 1 16cm x 22cm, flap closure

## To Sew

**1** Fuse all the interfacing pieces to the W/S of the corresponding fabric pieces, positioning the centre panel pieces and shoulder strap piece centrally widthways. Fuse the fleece to the W/S of the flap lining piece, positioning centrally and directly on top of the fused interfacing.



**2** Cut four 30cm lengths of bias binding and four 28cm lengths of piping cord. Lay a piece of cord along the centre of one binding piece, with a 1cm gap at both ends. Fold binding to enclose the cord and pin to keep cord at fold. Use a zip presser foot to stitch along the length, staying close to the enclosed cord. Repeat to make three more. Note: use a matching thread to blend in.



**3** Fold under the long edges of each centre panel, by 1cm, press. With R/S facing upwards, pin the folded edges close to the piping of each binding piece. Using the zip presser foot, topstitch close to centre panel folded edges.

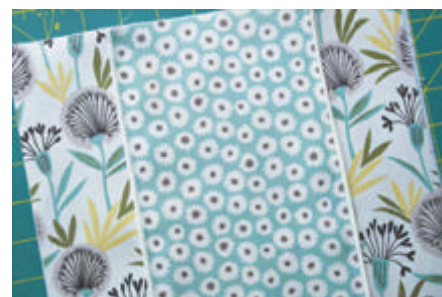

**4** Lay a centre panel on top of a main body outer, both R/S up and positioned centrally widthways. Pin. Topstitch 2mm in from the previous topstitching. Repeat to attach the other centre panel to other main body outer.



**5** With RST, sew the bottom edge of a top panel to the top edge of a main body outer. Repeat with other top panel and main body. Press the seams toward the top panels and topstitch 5mm from seams.



**6** Place the main body outers RST, matching up the centre panel seams at the bottom, pin. Stitch sides and bottom edge.



**7** Make the flat base by refolding the outer bag, RST, to match up the side seam with the bottom seam. Measure 3cm down from each corner and mark a

line across (it should measure approx. 6cm). Stitch the marked lines and trim off the corners to leave 5mm seams. Turn R/S out, easing all the edges out neatly.

**8** Cut a 70cm length of bias binding and piping cord. Lay the cord along the centre of the binding. Fold binding to enclose the cord and pin to keep at fold. Use the zip presser foot to stitch along the length using a matching thread, making sure you stay close to the enclosed cord.



**9** With the flap closure piece R/S up, align the open edges of the binding around the sides and bottom edge of the flap. Snip into the binding to help ease it neatly around the bottom corners, pin. Baste in place, close to the piping. Trim off the excess piping at the top edges of the flap.



**10** Place the flap and lining pieces RST, pin. Using the zip presser foot, stitch around the sides and bottom edge, staying close to the enclosed piping. Trim across the bottom corners and trim the seam allowance back to 5mm.



**11** Turn through to R/S, easing the corners out with a point turner and press. Topstitch close to the piping, using the zip presser foot. Baste the top raw edges together, with a 5mm seam.



**12** Pin the basted edge of the flap to the back of the outer bag, centrally and RST, matching up raw edges. Baste, 5mm from edge.



**13** Make the shoulder strap by folding in half lengthways, WST, press. Open out, W/S facing up. Fold long edges over to W/S, to meet at centre crease and press. Fold in half lengthways again, enclosing long raw edges, pin. Topstitch both long edges, using a 3mm seam.



**14** Pin the strap ends to the R/S top edge of the outer bag, matching the raw edges and positioning centrally across each side seam. Baste 5mm from the edges.



**15** Bag Lining – repeat step 5 to attach top panels to the lining pieces. Repeat step 6 to sew the lining pieces together, this time leaving a 15cm gap at centre of bottom seam for turning later. Repeat step 7 to make the flat base.



**16** Insert outer bag into lining bag, RST, matching up side seams and top edges, pin in place. Ensure the shoulder strap and flap remain hanging upside down between the layers. Stitch around top edges.



**17** Pull outer bag through the gap in the lining, so both are now R/S out. Fold in and press the edges of the gap in the lining to match rest of seam, pin. Stitch the gap closed, either by hand or machine stitch very close to the folded edges.

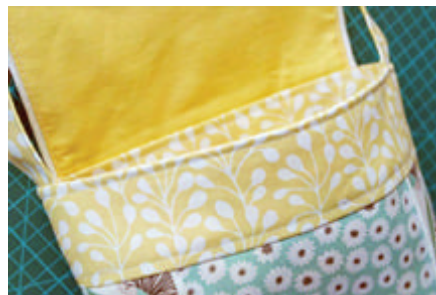

**18** Push lining bag down inside outer bag. Press the top edges of bag so the seam sits neatly at top. Topstitch all around opening of bag, 5mm from edge.

**19** Attach the riveted press snap parts to the flap closure and main body.

## Stockist Details

**Fabric and bias binding** – Eclectic Maker, [www.eclecticmaker.co.uk](http://www.eclecticmaker.co.uk), tel: 0845 862 5552

**Interfacing, fleece and piping cord** – SusieDDesigns, [www.susieddesigns.co.uk](http://www.susieddesigns.co.uk), tel: 07704 100 464

Name... Susan Dunlop

All About Me... I love sewing, adore modern fabrics and bags are my thing. Look out for my new bag-making book, *Style and Swing: 12 Structured Handbags for Beginners and Beyond*. Visit [www.susieddesigns.co.uk](http://www.susieddesigns.co.uk) for my range of patterns, supplies and kits.

Buy Susan's new book *Style and Swing, 12 Structured Handbags for beginners* for £16.99 with free p&p from [www.susieddesigns.co.uk](http://www.susieddesigns.co.uk). Signed copies available!



5 yards of delicate silk

1 Dual Feed for  
fine-fabric guidance

1 B 790 with  
Stitch Designer

3 Japanese embroidery  
motifs meaning  
"good fortune"

1 perfect fit for  
an overjoyed bride



*Kazu*  
**KAZU HUGGLER**  
SWISS-JAPANESE FASHION DESIGNER,  
FOR BERNINA



**The best technology for sewing and embroidery:** The **BERNINA 790** combines innovative functions and features with plenty of space, high speeds and an extra-large embroidery module. Use the colour touchscreen to effortlessly access all the functions. Discover something new and create your own stitches with the Stitch Designer. Drag and drop to edit embroidery motifs directly on the touchscreen. The fast and quiet BERNINA Hook sews high-precision stitches up to 9 mm in width and with the integrated BERNINA Dual Feed even hard-to-manage and fine fabrics can be sewn easily for superb results.

To find out more about the new BERNINA 720, 770 QE and 790, call 020 7549 7849, visit [www.bernina.co.uk](http://www.bernina.co.uk) or email [info@bernina.co.uk](mailto:info@bernina.co.uk)

\*conditions apply. 7 Year warranty valid on machines purchased between 1/8/2013 and 31/12/2015 from an authorised BERNINA UK stockist. See [www.bernina.co.uk](http://www.bernina.co.uk) for full details.



made to create **BERNINA**



*Embroidery:  
The window to your creativity.*

New ideas in mind? Embroidery threads from Mettler provide better stretch and higher tensile strength. And with their excellent sewability, extraordinary colour brilliance, and great durability, your embroidery will shine in the most beautiful colours.



Scan QR Code to search a dealer

AMANN  
GROUP

*Mettler*<sup>®</sup>

Thread.Colour.Imagination.



**Presencia**<sup>®</sup> Threads UK

7 Keel Court, Enterprise Close, Medway City Estate, Rochester Kent. ME2 4LY • T: 01634 711 228 • E: [waltonvs@aol.com](mailto:waltonvs@aol.com)

**Beautiful Threads**

We supply the best quality: Lace, Embroidery, Sewing, Quilting, Crochet, Tatting, Metallic, Rayon and Perlè threads (even Perlè Finca16, which can be used with a sewing machine) as well as 6 Ply Mouline embroidery floss.



**Finca**<sup>®</sup>  
PERLE



**Fincrochet**<sup>®</sup>



100% mercerized Egyptian 3 ply crochet cotton. Available in: 10, 20, 30, 40, 50, 60, 80 and 100 in white and cream ecru, weights 30 and 50 available in 6 bleach solid dyed colours.



**Presencia**<sup>®</sup> Threads UK

100% mercerized Egyptian 3 ply cotton thread in 50, 100m, 500m and 125g cones. 60/3 quilting thread in 600m & 125g cones.



100% mercerized Egyptian 2 ply cotton, in 5g. balls, weights: 12 and 16 and 10g. balls in weights: 3, 5, 8, 12 and 16, in solid dyed and bleach fast colours.

**Finca**<sup>®</sup> EMBROIDERY



100% mercerized Egyptian 6 ply cotton, in 8 meter skeins in solid dyed & bleach fast colours



**Finca**<sup>®</sup>  
METALLICS



100% Metallic Thread in 1, 2, and 6 ply, in 12 solid dyed colours.

For more information please see our web site: [www.bigginlance.co.uk](http://www.bigginlance.co.uk)

-----

This pretty empire line dress is bang on trend and perfect for this year's summer heatwave! With its fashionable square neckline, pleated straps and contrasting fabric hem panel, this light and floaty dress will help keep you cool. Wear to work, an evening out, on the beach or even over shorts or leggings, it will be a versatile addition to your summer wardrobe.

-----



DESIGNED BY Diane Allerston

# Here Comes the Sun!

## Summer Sundress

### Materials

- These beautiful hand block-printed organic cotton fabrics were kindly supplied by Offset Warehouse.
- 2 metres of 114cm wide fabric for main dress body and straps
- 0.5 metres of contrasting fabric for hem panel
- 0.5 metres interfacing
- 40cm – 45cm invisible zip
- Matching thread
- Optional – 0.5 metres lining fabric (if required)

### Good To Know

- *If the fabric is plain, it is easier and more cost effective. If you are using patterns, you will need to take the pattern repeat into consideration and match up the side seams and panels where possible, so you may need to purchase a little more fabric.*
- *If you are using slightly transparent fabrics, you should use the lining pattern pieces for the top section of the dress. Otherwise just use facings and interline.*
- *Seam Allowance – you will need to add your preferred seam allowance 1-2.5cm to the pattern pieces.*
- *Fabric width 114cm used throughout.*

### Main fabric layout

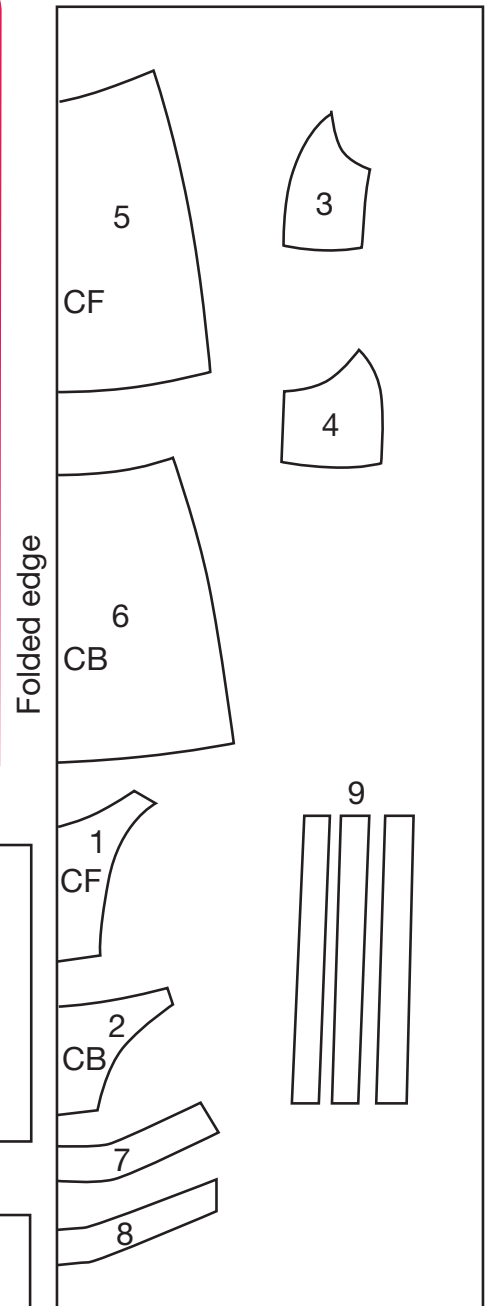

Sizing Chart:	Bust cm	Hips cm	Waist cm
12	100	104	84
14	104	108	88
16	106	112	92
18	110	116	96
20	114	120	100
22	118	124	104

### Interfacing layout

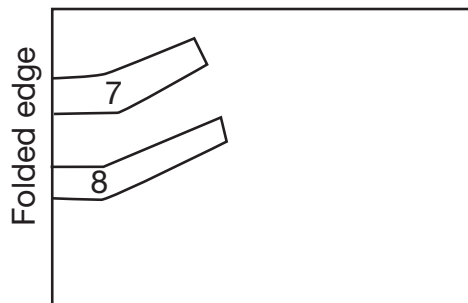

### Lining layout

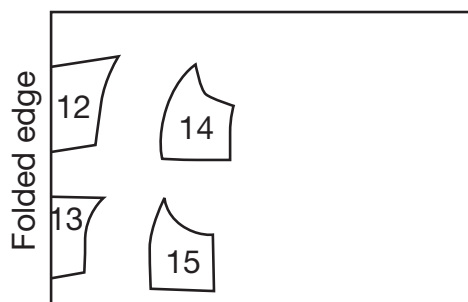

### Contrast fabric layout

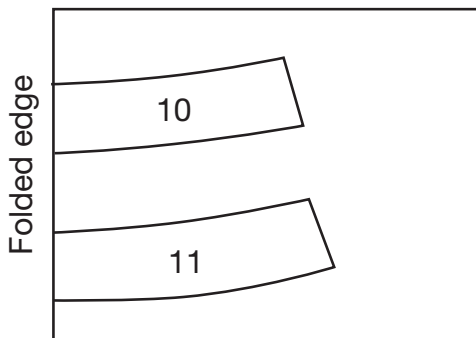

**To Cut** – See pattern sheet for pattern pieces. Also see Good to Know – remember to add a seam allowance.

**Main fabric:**

- Cut 1 top front panel on fold (1)
- Cut 1 top back panel on fold (2)
- Cut 2 side front top panels (3)
- Cut 2 side back top panels (4)
- Cut 1 front skirt panel on fold (5)
- Cut 1 back skirt panel on fold (6)
- Cut 1 front facing on fold (7)
- Cut 1 back facing on fold (8)
- Cut 6 straps (9)

**Contrast fabric:**

- Cut 1 front hem panel on fold (10)
- Cut 1 back hem panel on fold (11)

**Interfacing:**

- Cut 1 front facing on fold (7)
- Cut 1 back facing on fold (8)

**Lining fabric: (only cut if your fabric is slightly see-through, otherwise just use facing and interlining pattern pieces)**

- Cut 1 mid front lining on fold (12)
- Cut 1 mid back lining on fold (13)
- Cut 2 side front lining (14)
- Cut 2 side back lining (15)

**To Sew**

**1** Sew side front top panels (3) to mid front top panel (1). Press seams open.

**2** Sew side back top panels (4) to mid top back panel (2). Press seams open.

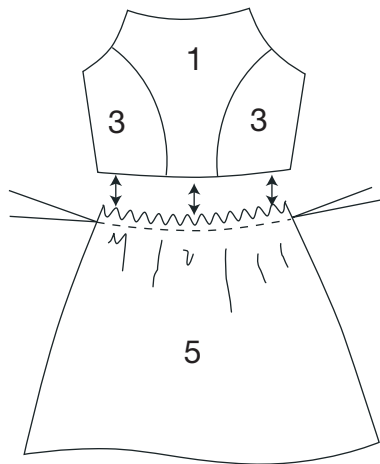
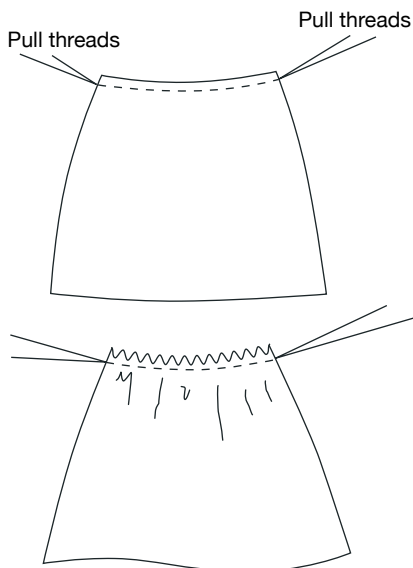

**3** Run a large gather stitch along the top edge of each skirt panel, front (5) and back (6) approximately 0.5mm down from top edge. Pull the threads holding each edge so that the skirt gathers. Separate the gathers so that the top skirt is the same length as the top dress panels.

**4** Adjust stitch length back to normal and attach the front skirt (5) to the front top panels and attach the back skirt (6) to the top back panels. Press seams open.

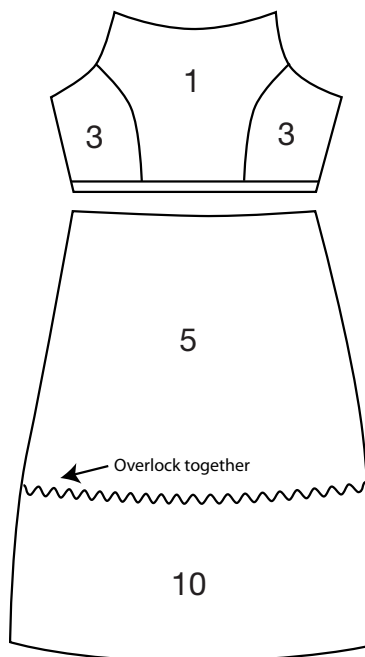

**5** Attach the front contrast hem panel (10) to the front skirt bottom and the back contrast hem panel (11) to the bottom of the back skirt panel. Press seams open and then overlock.

**6** Sew the dress front and back pieces together down the right side only. Press seam and then overlock the seam together.

**7** On the left side of the dress, overlock down the front and then the back side edge separately – this is where the zip is going to go. Measure from the underarm down the left side seam 40cm, leave this length open. Close the rest of the seam and press open.

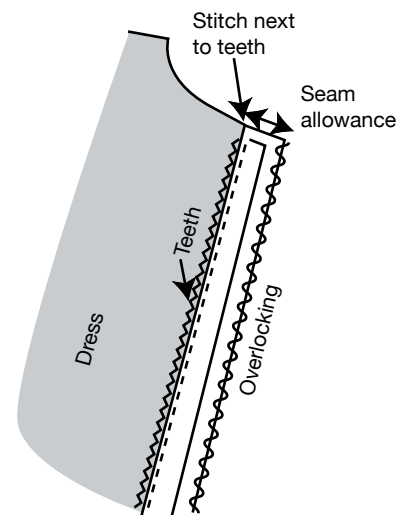
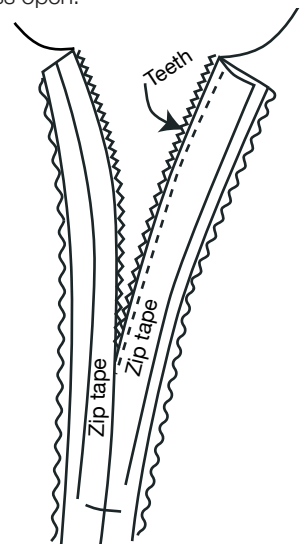

**8** Attach invisible zip using a zipper foot. Lay zip face down onto the seam, open the zip. Attach one side of zip, sewing through the zipper tape and the seam allowance only – not through the outer fabric. Peel the teeth back as you sew. Secure at the bottom. Repeat the process on the other side of the zip. Once attached, pull up zip from the back of the zip.



**9** Overlock hem edge of dress.

**10** Press up required hem (1-2cm) and topstitch.

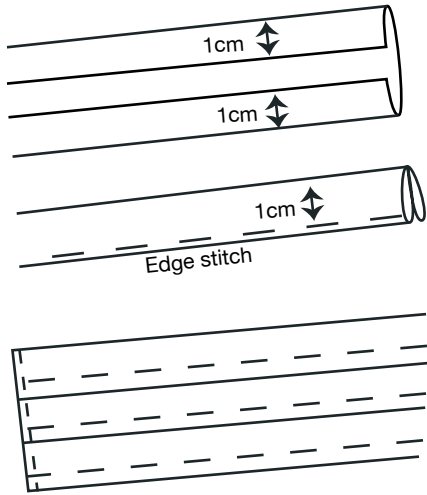

**11** Press the six straps 1cm in from each side, then fold in half and carefully machine stitch edge. Sew three straps together at the bottom and then plait together. Repeat so that you have two plaited straps. Secure the other ends once plaited.

Sew straps onto front

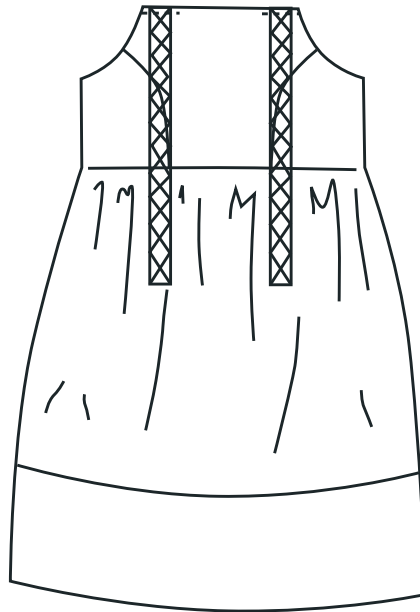

Interfacing facing you

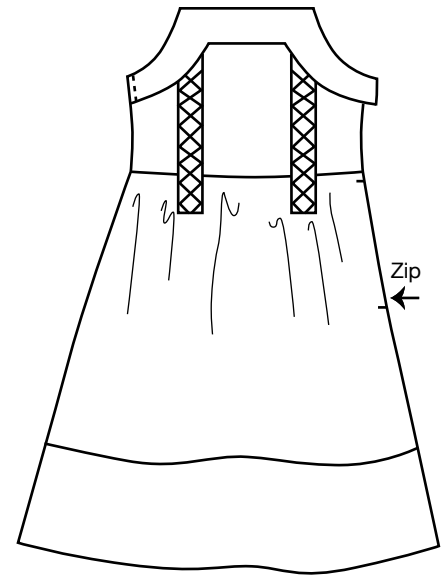

**12** Sew straps to the front of the dress only, at the position marked on the pattern.

**13** Sew or iron interfacings onto facings. The facings are going to be attached onto the outer (right) side of the dress with right sides together and then folded over to the inside of the dress to make a neat neckline edge. With right sides together, sew the front and back facings together down the right side seam.



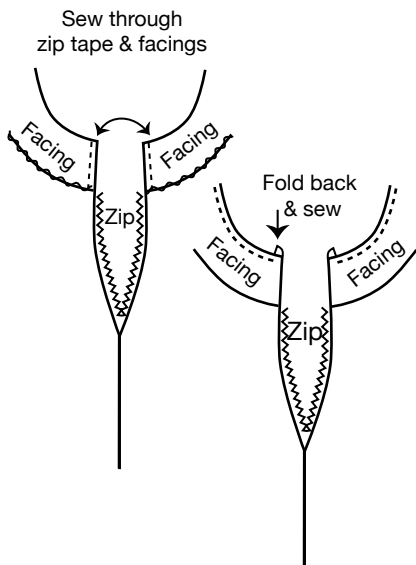

**14** Overlock the hem of the facing unless you are attaching a lining. (If you are attaching a lining, sew the side fronts to mid front and sew side backs to mid back lining, press seams open. Sew the right side seams, press open, then attach the neck facing to the lining). Position the facing onto the dress, with right sides together. Sew facing (and lining if using) down the zipper tape on the dress first, fold the facing seam allowance towards the back.

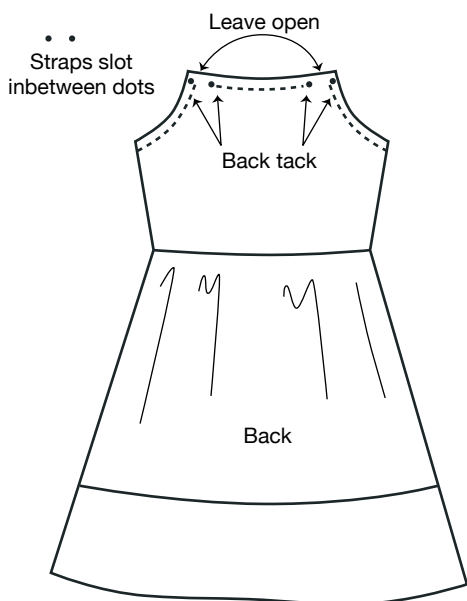
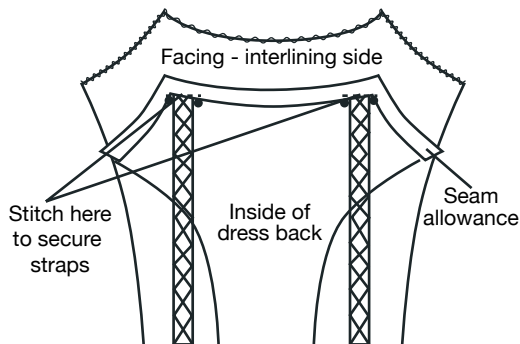

**15** Continue to attach the facing to the dress at the front and back neck and underarm, leaving open the marked area for the straps to slot into the back neckline.

**16** Push straps into the gaps that were left open at the back of the dress. Measure the required strap length (you may need to try on the dress to get the correct length for yourself). Pin in place and then secure through the seam allowance only with some machine stitches. Trim off any excess strap. You can trim the seam allowance around neck and underarm of dress and facing down to 0.5-1cm to help the seam lay flat.

**17** Turn so that facings are to the back and press the neckline. (If lining was attached – this can be slip stitched by hand to the empire line seam. Remember to press your seam allowance upwards at the empire line and then this seam will be hidden inside the lining.)

Enjoy your pretty, summer dress. x

## Stockist Details

Fabrics – Off Set Warehouse,  
[www.offsetwarehouse.com](http://www.offsetwarehouse.com)

Name... Diane Allerston

All About Me... I have worked in the fashion industry and within Higher Education for the past 18 years. I am a freelance fashion designer specialising in women's and children's wear and am also an illustrator. I have three really ace children who take up my whole life and fill it with happy stuff!

# Sundial Cushion

DESIGNED BY Ruth Lazarus

This project is an ideal opportunity to try out the different decorative stitches on your sewing machine and use up some of your fabric scraps. The back is equally smart with its neat three button fastening.



## Materials

- 50cm beige linen or linen look fabric
- 50cm lightweight iron on interfacing
- Eight, 25cm x 25cm of different coloured cotton fabric\*
- Three buttons
- Decorative thread
- General sewing thread
- Paper backed fusible web

\*You can alternatively raid your scrap bag for the circles on the cushion, you will need sixteen scraps at least 7cm x 7cm and sixteen scraps at least 3.5cm x 3.5cm.

## Good To Know

- Use a 7.5mm seam allowance
- Finished cushion measures 40cm x 40cm
- Covered buttons in fabrics from the same scraps add a nice detail on the back.

**To Cut** – See pattern sheet for pattern pieces

**From beige fabric and interfacing:**

One, 42cm x 42cm square for cushion front

Two, 42cm x 29cm rectangles for cushion back

**To Sew**

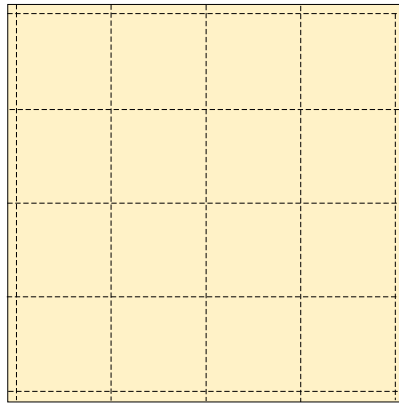

**1** Cushion front – iron the pieces of interfacing on to the beige fabric front and back cushion pieces. Take the 42cm x 42cm piece of beige fabric and using a non-permanent marking tool or a very fine pencil line, draw a line down from the centre of the piece. Draw two more vertical lines, 10cm apart, to the right of the centre and two more vertical lines, 10cm apart, to the left of the centre. Turn the fabric around by 90° and repeat the process, so that you end up with a 10cm grid.

**2** Trace the template for the larger circle on to the paper side of fusible web and cut out roughly. Iron on to one of your scraps, and cut out accurately. Peel off the paper backing and iron the circle on to one of the squares in your grid.

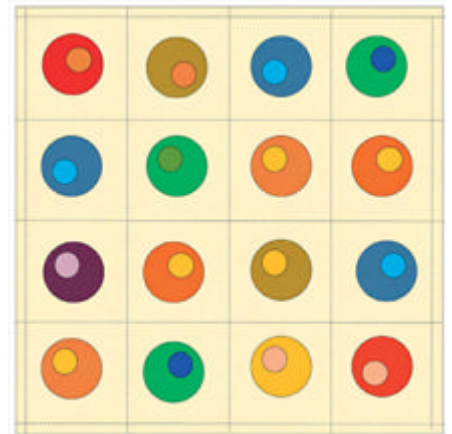

**3** Trace the template for the smaller circle on to the paper side of fusible web and cut out roughly. Iron on to a small scrap and cut out accurately. Iron the small circle on to the larger circle, slightly off centre. Repeat these steps to place a large and small circle in each square of your grid.

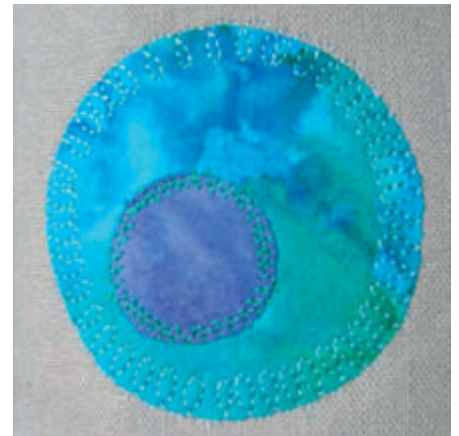

**4** If you have decorative stitches on your sewing machine, use a selection of these to surround the small and large circles. If you have no decorative stitches, then a zigzag stitch will also look just as effective. You can also stitch along the gridlines too in a contrasting thread.

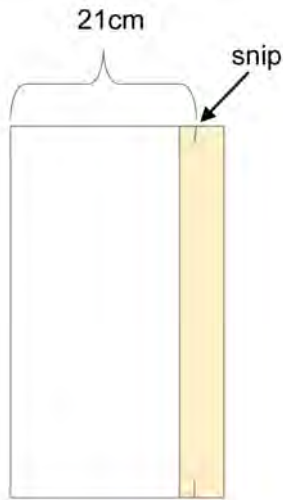

**5** The Cushion Back  
Press down a 5cm hem along the one long side of each back piece. Make a small snip, 21cm in from the unpressed edge, top and bottom.



**6** On one back piece, find the mid-point of the folded side and mark a buttonhole, 1.5cm in from the folded edge. Mark two more buttonholes 10cm either side of the middle. Use your machine to stitch the buttonholes.

Match snips here

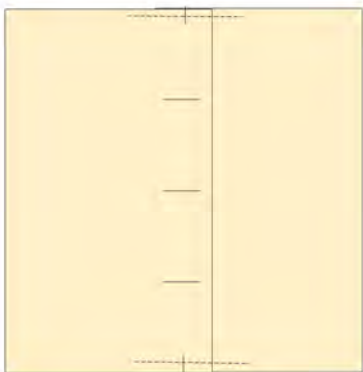

**7** Place the back pieces together (right sides up) with the buttonholed piece on top, matching them at the snips. Tack the pieces together at the overlap.

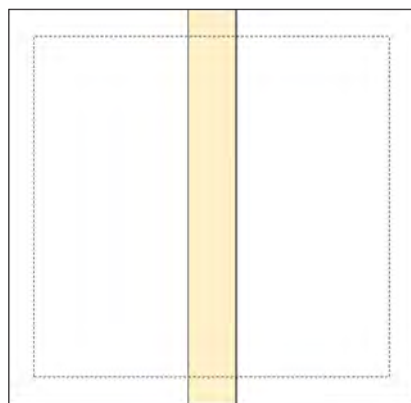

**8** Place the cushion front on top of the back (right sides together) and stitch all around with a 1cm seam.

**9** Trim the corners and turn the cushion right sides out. Stitch on the buttons.



Name... Ruth Lazarus

All About Me... I design and sell patterns for patchwork quilts, bags, cushions and soft toys and have contributed projects to magazines. I live in Manchester with my husband and when not sewing, I enjoy reading and films. My website address is [www.patchesandpots.co.uk](http://www.patchesandpots.co.uk)

# Yes! I want to subscribe to Sewing World magazine

## ORDER TODAY

- UK 1 Year (12 Issues) for only £52.99 and **save £18.89**
- UK 2 Year (24 Issues) for only £99.99 and **save £43.77**
- Only £11.75 every 3 months on Direct Debit (UK Only)
- Add a binder for only £9.95 + £2.95 p&p

Savings based on newsstand cover price.

For overseas prices see 'Not in the UK'

CODE:  
SW0615

Region: \_\_\_\_\_ Price £/US\$: \_\_\_\_\_

### My details: \_\_\_\_\_

Title..... Forename .....

Surname..... Address .....

Postcode ..... Country .....

Telephone incl. area code .....

E-mail.....

Traplet Publications Ltd may contact you with relevant information about other products and services related to your interests.

Please tick this box if you DO NOT want to be contacted by Traplet Publications . Traplet Publications will never sell your details to any third party.

### I would like to send a gift subscription to: \_\_\_\_\_

*Please also fill out 'My Details' section above. To give more than one gift subscription, please supply address details on a separate sheet.*

Title..... Forename .....

Surname ..... Address .....

Postcode ..... Country .....

Telephone incl. Std code .....

E-mail.....

### I am using the following payment method: \_\_\_\_\_

**CHEQUE** I enclose a cheque for \_\_\_\_\_ (made payable to Traplet Publications Ltd.)

**CREDIT/DEBIT CARD** Please debit the amount of \_\_\_\_\_ from my:

Visa  Mastercard  American Express  Switch/Maestro

CARD NUMBER

\_\_\_\_\_

EXPIRY DATE

VALID FROM

SEC. No

(FROM BACK OF CARD)

ISSUE. No

\_\_\_\_\_

\_\_\_\_\_

\_\_\_\_\_

\_\_\_\_\_ (SWITCH/ MAESTRO ONLY)

Signature \_\_\_\_\_ Date \_\_\_\_\_

I understand that £11.75 will be debited from my account every 3 months. Please complete the Direct Debit form below.

#### Instruction to your Bank or Building Society to pay by Direct Debit

For office use only - Service User No. 599211

Ref. No. \_\_\_\_\_



Please fill in the form and send to Traplet Publications, Traplet House, Willow End Park, Blackmore Park Rd, Malvern WR13 6NN.

Name of Bank: \_\_\_\_\_

Address: \_\_\_\_\_

Postcode: \_\_\_\_\_

Account Name: \_\_\_\_\_

Sort Code: \_\_\_\_\_ Account No: \_\_\_\_\_

Please pay Traplet Publications Ltd., Direct Debits from the account detailed in this instruction subject to the safeguards assured by the Direct Debit Guarantee. I understand that this Instruction may remain with Traplet Publications Ltd., and if so, details will be passed electronically to my Bank/Building Society

Signature \_\_\_\_\_ Date \_\_\_\_\_

#### The Direct Debit Guarantee (This guarantee should be detached and retained by the Payer)

- This Guarantee is offered by all banks and building societies that accept instructions to pay Direct Debits
- If there are any changes to the amount, date or frequency of your Direct Debit Traplet Publications Ltd. will notify you seven working days in advance of your account being debited or as otherwise agreed. If you request Traplet Publications Ltd. to collect a payment, confirmation of the amount and date will be given to you at the time of the request.
- If an error is made in the payment of your Direct Debit, by Traplet Publications Ltd. or your bank or building society, you are entitled to a full and immediate refund of the amount paid from your bank or building society
- If you receive a refund you are not entitled to, you must pay it back when Traplet Publications Ltd. asks you to
- You can cancel a Direct Debit at any time by simply contacting your bank or building society. Written confirmation may be required. Please also notify us.

# A subscription makes the perfect gift!

🌸 Spread the cost with Direct Debit

🌸 Get all your inspiration hot off the press

🌸 Every issue delivered straight to your door

🌸 Get your issues before they hit the shops

## Not in the UK?

Don't worry here are our overseas subscription rates

### OVERSEAS SUBS RATES

Region	1 Year	2 Years
Europe	£64.00	£124.00
USA & Canada	US\$89	US\$169
Worldwide	£65.00	£127.00

Overseas orders: please complete coupon and return to Traplet Publications, Traplet House, Willow End Park, Blackmore Park Rd, Malvern WR13 6NN based on a 2 year cover price

## DIGITAL VERSION



**Sewing World magazine is now available in a digital format!**  
To buy your digital edition, to read on a pc or mac, go to [www.pocketmags.com](http://www.pocketmags.com)

# Subscribe today

and receive a beautiful

SUBSCRIBE  
FROM AS  
LITTLE AS  
£11.75\*\*



## Fox and Friends Fabric Roll\*!



HEAD.SUBS.SW/JUN15

# SUBSCRIBE TODAY!

## And Get A Free Lewis & Irene Fabric Roll



+44 (0) 1684 588599



[shop.inspiredtomake.com](http://shop.inspiredtomake.com)

Complete the coupon opposite and send to: (UK only) Freepost RTRS-XEGS-CJET, SW Subscriptions, Traplet Publications Ltd, Willow End Park, Blackmore Park Road, Malvern, WR13 6NN

Prices correct at time of going to press and may be subject to change without further notification. This offer is not to be used in conjunction with any other offer. Your subscription will begin with the next available issue. If you wish to cancel your subscription, please notify us to make arrangements. Direct Debit cancellations can be carried out but no refund will be issued, for one-payments, requests for a refund must be in writing. Refunds will be made at the Publishers discretion. An administration charge of 15% of the remaining credit may be deducted from the refund issued. \* The Fox and Friends pattern is subject to availability. Once this fabric has sold out a substitute pattern will be dispatched. \*\* £11.75 is the Direct Debit Subscription rate taken every 3 months.

# Lamifix Cosmetic Purse

DESIGNED BY Laura Strutt

create your own wipe-clean cosmetic purse. With the addition of Vilene Lamifix to your favourite pretty print cottons and using the finishing touch of a lovely lace zip, this make is a quick and easy weekend project!



## Materials

- 23cm x 30cm (9" x 12") of fabric A: SBlu 1064 September Blue by Susan Driscoll from Dashwood Studio
- 23cm x 30cm (9" x 12") of fabric B: Fleur 2000 Blush, September Blue by Susan Driscoll from Dashwood Studio
- 23cm x 30cm (9" x 12") of Vilene Lamiflex Matt
- 23cm x 30cm (9" x 12") Vilene Lamiflex Gloss
- 23cm (9") Lace Zip
- Iron and pressing cloth
- Pinking Shears

## Good To Know

- Use  $\frac{1}{4}$ " seam allowance throughout.
- Vilene Lamiflex is a fusible laminating product available in both matt and gloss finish. It is applied with the heat of an iron to create a wipe-able finish to your fabrics.
- Finished Measurements 8" x 6 $\frac{3}{4}$ "



## To Cut

Cut the fabrics using the rotary cutter and ruler.

- Cut 1, 9" x 12" from fabric A – main fabric
- Cut 1, 9" x 12" from fabric B – lining
- Cut 1, 9" x 12" from Lamiflex matt
- Cut 1, 9" x 12" from Lamiflex gloss

## To Apply the Lamiflex



**1** Place the fusible surface of the Lamiflex Matt onto the right side of fabric A, smoothing out any wrinkles by hand and cover carefully with a pressing cloth. With the iron on a cotton setting, position and hold the iron onto the surface for eight seconds, lift and reposition. Repeat until the entire surface has been bonded. Leave the fused section to cool and repeat to bond the Lamiflex Gloss to the right side of fabric B.

## To Sew



### **2** Seam the fabrics

Once your fabric has cooled, place the two pieces together with rights sides facing. Aligning the shorter edges join with a  $\frac{1}{4}$ " seam along the short side. Repeat to join the second short side.



### **3** Turn through and press

Turn the joined fabrics through to the right side. Gently ease out the seams. Working on each end in turn, cover with the pressing cloth and neatly press the seams flat.



### **4** Secure the first side of the zip

Align the side of the lace zip along one of the seamed edges of fabric (both zip and fabric are right side facing upwards). Secure in place with neat machine stitches. When approaching the zip tab, stop the machine with the needle in the down position; ease the zip past the foot before continuing to sew the remaining section of the zip.



**5 Secure the second part of the zip**  
Align the lace zip along the second seamed edge of the purse. In order to sew in place without stitching through the rest of the purse fabric – fold the purse so that the secured part of the zip is on the left-hand side and the zip teeth are facing down. The second half of the zip can be positioned against the short edge of the remaining side and secured in place. When approaching the zip tab, stop the machine with the needle in the down position, and ease the zip past the foot before continuing to sew the remaining section of the zip.



**6 Create the purse**  
With the zip opened, turn the bag through so that the wrong side is outermost. Position the zip so that it lies in a straight horizontal line across the purse and sits 2" from the folded upper section, finger press in place. Working on each end in turn, join the end seams with a neat ¼" seam allowance – carefully ensuring that the machine doesn't work over any metal sections of the zip. Repeat to create the second end seam.

**7 Neaten and turn through**  
With the pinking shears, neatly trim the seam allowance on both of the end seams, ensuring that you don't snip through the stitches. Through the open zip, turn the purse through to the right side, neatly easing out the corners. Cover the purse with the pressing cloth and press neatly to finish.



## Stockist Details

September Blue by Susan Driscoll from Dashwood Studio – [www.dashwoodstudio.com](http://www.dashwoodstudio.com)

Lace Zip – Plush Addict, [www.plushaddict.co.uk](http://www.plushaddict.co.uk)

Vilene – [crafts@stockistenquiries.co.uk](mailto:crafts@stockistenquiries.co.uk)



Name... Laura Strutt

All About Me... Laura Strutt is a designer maker and the author of *The Sewing Manual* (2013, Haynes), *The DIY Wedding Manual* (2014, Haynes) and *Arm & Finger Knitting* (2015, CICO). She shares free projects, how-to guides, tutorials, recipes and handmade inspiration daily on her creative lifestyle journal [www.madepeachy.com](http://www.madepeachy.com)



# JANOME

The World's leading sewing machine manufacturer

*Sewing*  
with **STYLE**

# SEWDEVINE

www.sewdevine.co.uk

Sew Devine  
24 Wokingham Road  
Reading, Berkshire  
RG6 1JQ

## TWO DAY IN-STORE EVENT

**Friday May 22nd 9.30am - 5pm**

**Saturday May 23rd 9.30am - 4pm**

Come and meet **Jayne Brogan** from **Janome** who will be demonstrating all the latest sewing, quilting and embroidery machines.

**BONUS**  
**FREE SOFTWARE**  
**Digitizer Jr**  
**Normally £249**

**SALE**  
**£899**  
SAVE £100



Model MC350E

**GREAT OFFERS ON THE**  
**Memory Craft**  
**8900QCP & 8200QC**

**FREE**  
**DELIVERY**

The MC350E has the Janome exclusive built-in embroidery unit, it offers professional-style embroidery and the display screen tells you everything you need to know. Choose from one of the built-in designs or download from the internet. Resize, edit or combine designs to make your project unique.

**LOTS OF SPECIAL**  
**OFFERS ON THE DAY**

**FREE**  
**DELIVERY**

**BONUS**  
**FREE Quilting Kit &**  
**Extension Table**  
**Normally £119**

**SALE**  
**£299**  
SAVE £50



Model XL601



An ideal machine for anyone to use, it has plenty of stitch options for creating all kinds of projects. It's easy to use features make sewing a pleasure. Fully computerised, yet still light enough to carry to classes .. it's a full size machine but less than 6kg.

**FREE DELIVERY UK MAINLAND**

**FREE CAR PARK VIA EASTERN AVENUE**

Sew Devine for all your sewing needs.....

**Order Line:**

**0118 926 8664**

# Fun in the sun!

## Summer sun-top and skirt

This little girl's sun top is great for summer fun in the garden! It has a large sash bow at the back to make it girly and frivolous. Drop the straps and turn it into a pretty summer skirt.

DESIGNED BY Julia Claridge of Bobbins & Buttons.

## Materials

- 100cm main fabric – Cotton print, I used Tulip Patch by Ellen Medlock
- 20cm contrast fabric for facing and sash, I used pink polka dot cotton
- 10cm lightweight iron on interfacing
- 60cm of 2cm wide elastic
- 2, 1.5cm buttons

## Good To Know

- Use 1.5cm seam allowance throughout.
- 114cm fabric width is used throughout.
- Pick fabrics carefully when making your sun-top/ skirt. Watch out for directional prints and try to keep any pattern going the same way. If there is a large pattern repeat, it may be necessary to buy a little extra fabric. Make sure your fabric does not look upside down when you sew the top together!

Sizing Chart:	Age 3-4	Age 4-5	Age 5-6
Chest	54	56	58
Length from top of strap to hem	43	45	47
Elastic measurement for back – adjust as necessary	27	28	29

**To Cut** – See pattern sheet for pattern pieces

### Main fabric:

- Cut 1 back on fold (1)
- Cut 1 front on fold (2)
- Cut 2 straps (3)
- Cut 1 pair sash ties (4)
- Cut 1 yoke on fold (5)

### Lining fabric:

- Cut 1 pair sash ties (4)
- Cut 1 yoke on fold (5)

### Interfacing:

- Cut 1 yoke on fold (5)

## To Sew



**1** Prepare the straps. With right sides together, stitch each strap down the length. Turn through and press.



**2** Cut two pieces of elastic, each measuring 13cm long. Make a small mark with tailors chalk 16.5cm from the end of the back of the strap. If you are using a one way print – double check the pattern is not upside down.



**3** Insert the elastic into the strap using a safety pin, start from the top of the strap until you can feel the edge of the elastic at the point where you made the mark. Stitch elastic in place.

**4** Once the elastic is secured at this point, push the safety pin to the end of the strap. Carefully turn in the ends of the strap and sew in place.



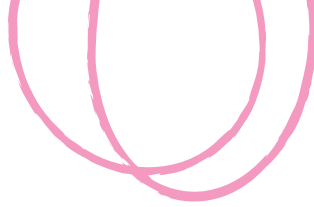
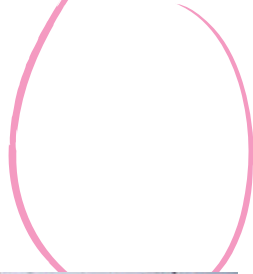

**5** Prepare the yoke. Apply the iron on interfacing to the reverse of the outer yoke panel. Turn and press the seam allowance at the lower edge of the lining yoke panel.

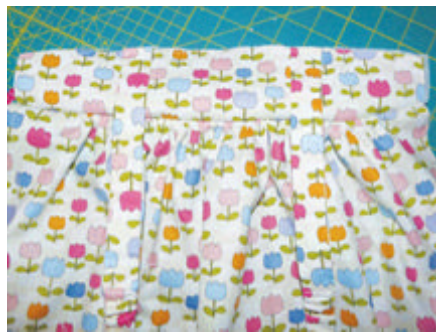

**10** Place the sash ties right sides together at each side front, gather to fit the side yoke. Stitch in place to hold.



**6** Sew two rows of running stitches along upper edge of front panel. Matching centre points together, gather to fit the outer yoke panel. Stitch in place.

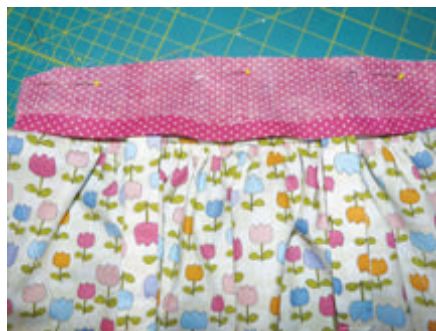

**8** Stitch the flat, front end of the straps right sides together at the top edge of the yoke. Place the facing panel right sides together over the front yoke panel. Stitch in place. Press the facing to the inside.



**11** Join side seams – turn the facing over back panel to conceal all seams. Stitch in place. Finish the edge of this seam with a zigzag stitch or overlock. Press seam to front of garment.

**7** Prepare the back panel. Turn and press 1.5cm along upper edge followed by 3.5cm turning to form a channel for the elastic. Stitch in place. Cut elastic to length and insert into the channel, stitch at either end to hold in place.

**9** Prepare the sash. Place one outer fabric and one lining fabric sash piece right sides together, stitch around edges leaving the straight, short edge open. Trim, turn and press. Stitch two rows of gather stitches across the end.





**12** Pin the yoke lining along seam line and slip stitch by hand.



**13** Work a button hole on the end of each strap (try the top on your child and adjust the position of buttonhole to fit). Use a pin to hold the fabric flat while you work the buttonhole. Sew a button to the inside of the back elastic channel (try the top on the child for the ideal button position if possible). Alternatively stitch the button adjacent to the front strap – be careful not to catch the elastic when you sew the button on.



**14** Turn a narrow double hem along the bottom edge of the sun top and stitch.



## Stockist Details

Fabrics – Hannah's room  
[www.hannahsroom.co.uk](http://www.hannahsroom.co.uk), tel: 07891 056908

✂✂✂  
**Name...** Julia Claridge

**All About Me...** I run a small business called Bobbins & Buttons, based in Leicester. My two small children aged 3 years and 5 years old inspire most of my creations. I design children's clothing and sewing projects some of which I make to order and all of which I teach in my sewing workshops and courses. I write a blog about my handmade wardrobe and the pursuit and development of my children's clothing styles. Find me at [bobbinsnbuttonsblog.wordpress.com](http://bobbinsnbuttonsblog.wordpress.com) or [www.bobbinsnbuttons.co.uk](http://www.bobbinsnbuttons.co.uk)



# Funky Key Fob

DESIGNED BY Claire Muir

These bright and colourful key fobs are fun to make and are a brilliant way to use up small pieces of fabric. Experiment with materials and enjoy personalising them. They make a great gift!



## Materials

- 16cm x 16cm of medium weight calico
- 10cm x 7cm hobby felt or wool felt (usually comes in 22.9cm x 30.5cm sized pieces)
- 15cm x 10cm transfer adhesive (Bondaweb)
- 10cm x 7cm Pelmet Vilene Classic (S80/239)
- Small pieces of dupion silk
- 2, 8mm/1cm buttons
- 7cm x 1cm wide ribbon
- Black viscose machine embroidery thread
- 1, 24mm flat split nickel key ring
- Piece of baking parchment paper
- 13cm diameter wooden embroidery hoop

## Good To Know

- Use a  $\frac{1}{4}$  inch foot on your sewing machine if you have one. You can do a narrow zigzag stitch with it, and its narrow foot enables you to sew around the calico without hitting the buttons.
- Finished fob measures approximately 9cm x 5.5cm.
- Using fabric cut on the cross, helps prevent it fraying when you sew the outline stitching around the car.
- There are other stiffening fabrics which are suitable. I have used milliner's buckram which is already self-adhesive on both sides.
- The self-adhesive heavy weight Vilene is too thick to machine stitch through for this project.
- The baking parchment will help prevent you melting the felt!
- An easy way to stitch lettering: write on tissue paper, stitch through both the tissue and fabric and then tear it away.

**To Cut** – See pattern sheet for pattern pieces

### Calico:

– Cut 1, 16cm x 16cm square

### Felt:

– Cut 1, 10cm x 7cm piece

### Vilene:

– Cut 1 of pattern piece

### Transfer adhesive/Bondaweb:

– Cut 1 of each of the pattern pieces

**2** Trace the pattern pieces of the car facing to the right, onto the paper side of the Bondaweb. Iron onto three different coloured pieces of silk and fussy cut out.



## To Sew



**1** Iron Bondaweb to both sides of the pelmet Vilene. Keep the backing paper on both pieces.

**3** Peel off the backing paper from the car body piece and iron to the calico, making sure that you place it in the middle so that you will be able to fit it in the hoop easily. Peel off the paper from the other car pieces and iron the windows and the bumper to the car. Put the calico in the wooden hoop and pull the fabric until it is really taut.



**4** Set up your sewing machine for free-machine embroidery and attach the free motion embroidery foot. Put black viscose machine embroidery thread in the bobbin and on top. Begin to free-machine embroider around the edge of the car twice. Sew around the bumper twice and then continue around the windows.



**5** Machine embroider the line details for the door handle, lines around the wheels and headlight.

**6** Keep your work in the hoop and hand sew on the buttons using a double thickness of sewing thread.

**7** Remove the work from the hoop. Take the pelmet Vilene and when you have worked out which way round you need it to be, remove the backing paper. Iron the calico to one side of the pelmet Vilene and cut the surplus calico away. You will need to iron around the buttons.

**8** Remove the backing paper from the other side of the Vilene and position on your piece of felt. Allow quite a wide border of felt as it is easier to sew it like this, but you will need to trim it down after you have stitched it. Fold your ribbon in half and place the cut ends between the Vilene and the felt at the top of the key fob. Tuck the ribbon in a good 1cm from the edge of the calico. Place the piece of baking parchment over the fabrics and iron to fuse together.



**9** Set your machine back to normal sewing. With a thread matching the felt in the bobbin and a top thread that matches the calico, zigzag stitch the calico to the felt. Start you stitching at the top where the ribbon is so that when you finish, sew over the ribbon for a second time, making sure it is nice and secure.

**10** Trim the felt so that you have a narrow border and attach the split ring to the ribbon.



## Stockist Details

Calico – Frumble, [www.frumble.co.uk](http://www.frumble.co.uk), tel: 0121 224 7383

Pelmet Vilene and Bondaweb – Kim Thittichai, [www.nid-noi.com](http://www.nid-noi.com), tel: 07986 417150

Felt – Hobbycraft, [www.hobbycraft.co.uk](http://www.hobbycraft.co.uk), tel: 0330 026 1400

Flat split nickel key ring – BFNT, [www.bfnt.co.uk](http://www.bfnt.co.uk), tel: 07956 933057

Name... Claire Muir

All About Me... I love free-machine embroidery and enjoy teaching it, talking about it and doing it! I teach a variety of workshops above Frank Nutt's Sewing Machine Shop in Kings Heath and at Denman College in Oxford. When I'm not teaching, I'm creating bespoke bridal accessories from flowers to fascinators, brooches to butterflies – all embroidered of course! My website is [www.clairemuir.co.uk](http://www.clairemuir.co.uk) and Facebook is Claire Muir Textiles

**FN**  
**FRANK NUTT**  
SEWING MACHINES



**3 ways**  
**to buy**  
On the telephone,  
in the showroom  
or online.

Our showroom is located in Kings Heath, Birmingham, West Midlands where we have over 60 working sewing machines on display ready for demonstration. Don't forget we have our own car park next to the showroom.

We are official stockists of **Babylock**, **Brother**, **Bernina**, **Janome**, **Singer**, **Elna**, **Bernette** and **Juki** Sewing Machines & Overlockers along with **Horn Cabinets** and **Ajustoform Dressmaking Dummies**.

Creative machine embroidery workshops by Claire Muir. Training also available.

Give us a call on 0121 444 3978 for lots of honest, helpful and friendly advice.



**Come and**  
**see the new**  
**Bernina 7 series**

Free next day delivery on all machines  
in stock ordered before 2pm

**www.franknutt.co.uk** | **HOTLINE**  
**0121 443 5555**

Frank Nutt Sewing Machines, 17 - 23 Poplar Road, Kings Heath, Birmingham. B14 7AA Est.1985.

# Criss-cross Table runner set

DESIGNED BY Lou Orth

This quilted table runner set is a great way to brighten up any occasion. It has a modern cross design and uses bright blue fabrics against a fresh white background - all from the celebrated new American design collaborative Cotton + Steel.



## Materials

- 50 x 55cm (1 fat quarter) XOXO in Night Owl, Cotton + Steel Basics
- 50 x 55cm (1 fat quarter) Netorius in Teal, Cotton + Steel Basics
- 50 x 55cm (1 fat quarter) XOXO in On the rocks, Cotton + Steel Basics
- 50 x 55cm (1 fat quarter) Dottie in Bluebird, Cotton + Steel Basics
- ½m Toy Boat (plain), Cotton + Steel Solid
- ¾m Kerchief (plain), Cotton + Steel Solid
- ½m Wadding



### XOXO in On the Rocks:

- Cut 10, 3½" squares (Table runner)
- Cut 5, 2" squares (Coasters)

### Dottie in Bluebird:

- Cut 7, 3½" squares (Table runner)
- Cut 5, 2" squares (Coasters)

### Kerchief Solid:

- Cut 4, 2½" x 24" strips for binding Coasters
- Cut 2½" x 110" strip for binding Table runner (cut several strips along width of fabric and sew together until you have a strip 110" long)
- Cut 20, 3½" squares (Table runner)
- Cut 16, 2" squares (Coasters)

### Toy Boat Solid:

- Cut 1, 45" x 13" for Table runner backing
- Cut 4, 5½" squares for Coaster backing



## Good To Know

- Use ¼" seam allowance throughout.
- Fabric width used is 114cm throughout.
- Finished table runner size 42" x 12".
- Finished Coaster size 4½" x 4½".
- RST – right sides together.

## To Sew

**1** To make the table runner, use the layout design as guidance and sew together the 3½" squares in rows of 4 squares long. Sew the rows together to make the table runner 14 rows tall.

**2** When you have completed your table runner top, create a quilt sandwich by placing the wadding in-between the runner top and the Cotton + Steel plain in Toy Boat at the bottom (both the right sides of the table runner top and bottom needs to face outwards). Use safety pins to hold the sandwich in place and quilt using diagonal lines. Trim down any excess wadding.

## To Cut

### XOXO In Night Owl:

- Cut 10, 3½" squares (Table runner)
- Cut 5, 2" squares (Coasters)

### Netorius in Teal:

- Cut 9, 3½" squares (Table runner)
- Cut 5, 2" squares (Coasters)





**3** To bind, take your strips of the Kerchief plain for the binding and fold in half, so that it is 1¼" each side and press in place with an iron. Attach your binding by lining up raw edge of binding to raw edge of table runner top with RST; sew all the way around the edge of the table runner. Fold binding over to the back, take a small turning and hand stitch in place.



**4** To make the coasters, use the layout cross design as shown and sew together the 2" squares so that they form a block of 3 by 3.



**5** As with the table runner, create a quilt sandwich (use the left over wadding and backing from table runner) and again quilt diagonally.

**6** To bind, follow the instructions as detailed in step 3, using the shorter strips cut for the coasters.

## Stockist Details

Fabrics and wadding – Simply Solids, visit [www.simplysolids.co.uk](http://www.simplysolids.co.uk)

Name... Lou Orth

All About Me... I'm a self-confessed fabric addict from Oxfordshire. I love to create sewing projects including quilting and dressmaking. And you can find me blogging about my sewing makes and tutorials on [www.imstudiolou.wordpress.com](http://www.imstudiolou.wordpress.com). You can also find me on Instagram, Pinterest and Twitter as @imstudiolou

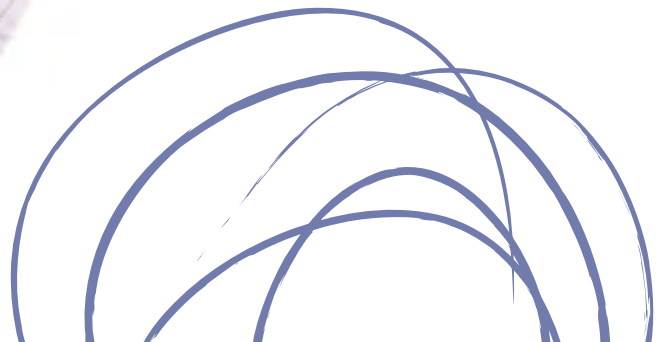

# Bear Cushion

DESIGNED BY Michelle Kreussel

This bear cushion uses soft neutral colours that would suit any nursery and is both practical and decorative. The bear is adorable on its own or nested in amongst other animal-cushion friends!



## Materials

- 2 x pieces of fabric 30cm square (natural, unbleached linen was used here)
- 4 x pieces of wool felt in different colours
- Air-erasable pen
- Scissors
- Embroidery hoop
- Embroidery needle
- Pins
- Embroidery thread in colours to coordinate with the pieces of wool felt
- Hand-sewing needle and thread (or sewing machine)
- Chopstick or knitting needle
- Polyester fiberfill
- Optional – lightbox

## Good To Know

- *This project should take you around five hours to make.*
- *Why not try free-motion embroidery to stitch down the bear's face features.*
- *Try using stitching to stitch this bear cushion together and make it even more 'handmade'.*
- *You could scale the pattern pieces up or down to make your own family of bears!*

**To Cut** – See pattern sheet for pattern templates

**Main fabric/linen:**  
– Cut 2, 30cm square

**Felt:**  
– Cut 2 cheeks  
– Cut 2 eyes  
– Cut 1 oval nose  
– Cut 1 triangle nose  
– Cut 2 inner ears

## To Sew



**1** Trace the bear template provided onto the right side of one piece of fabric. It is useful to draw over a lightbox if you are using dark fabric, but with a lighter fabric you won't need one. Make sure to trace the same line on the wrong side of the fabric because you will need to sew on this line.



**2** Cut out the shapes from the felt for the bear's features and place down onto your main fabric. Place the fabric in the embroidery hoop to keep it taut.



**3** Embroider the felt features onto the right side of the face of the bear. Use running stitch to sew on the ears, cheeks and nose, and embroider the mouth in backstitch.



**4** Place the right sides of the fabric together and pin. Sew together with a sewing machine, or use running stitch if sewing by hand. Leave a 7.5cm gap in the side of the bear for stuffing.



**5** Cut around the outline of the bear, leaving a 1.3cm gap between the outline and the cutting line.





**6** Cut out little triangles all around the edge of the bear. This will help to ensure the fabric does not pull when you stuff it. Be careful not to cut over the sewing line.



**7** Turn the bear right side out. Use a chopstick or knitting needle to push out the fabric in the corners and other narrow areas, such as the ears.

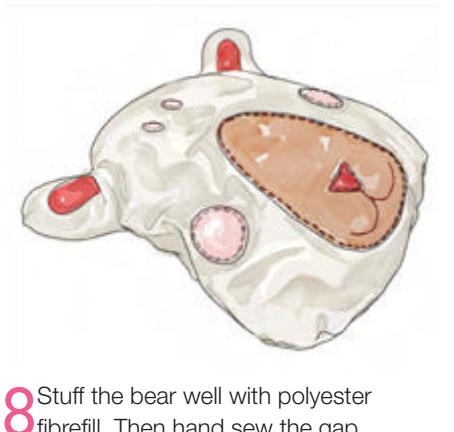

**8** Stuff the bear well with polyester fibrefill. Then hand sew the gap closed, using hemming stitch.

Michelle Kreussel from St Leonards-on-Sea in East Sussex, is known for the cushions, dolls and embroidery crafts she creates for The Fox in the Attic.

This project is an extract from *Handmade for Baby – 25 Keepsakes to Create with love* by Charlotte Rivers & Emily Gregory. Published by Apple Press, priced at £12.99.



*Justhands-on.tv*

**www.Justhands-on.tv**

The UK's online TV channel for patchwork, quilting and textile art

**Join us online and have the classes come to you**



Make this scrap quilt with us in just 40 minutes

Enjoy demonstrations, tips and stand alone workshops from the UK's top quilting tutors, and wander around quilt shows, galleries and museums with us for inspiration.

1000's of hours of professionally made videos, online 24/7

**FREE registration and content**    **NEW videos every Friday**

**A wealth of information and inspiration at your fingertips.....**

# Scratchin' Chicken

## Bag Recycler

DESIGNED BY Debbie von Grabler-Crozier

No matter how hard we try some plastic bags just seem to creep into the house. Keep them tidy and handy in this easy to make hanging store.

This bag uses appliqué and free-motion embroidery to 'doodle' the funky chicken and flower design. The floral and polka dot fabrics look great together on the lovely earthy linen.

### Good To Know

- This project uses a glue stick instead of a fusible fabric bond. Why I hear you ask?! Well for one, it is cheaper. It's also more precise on small pieces and less messing around with irons and so it's also quicker. Don't saturate the piece though – just use enough to make the appliqué piece stay in place whilst you sew.
- Free-motion embroidery is all the rage at the moment. This project uses raggedy edged appliqué and contrasting thread over the top and is a sort of stitch doodling! Most sewing machines can do this, you will need to use a darning foot and to either drop the feed dogs on your machine or set the stitch length to zero. Slowly move the fabric around to achieve a stitch outline or doodle.
- This embroidery looks best if you go over it twice and don't be too neat. Use the black thread.
- The elastic allowance and usage is deliberately vague. I have used a little less in the top to make it a little tighter and more at the bottom because this is where most of the 'action' is. If it is too tight, it is more likely to tear.
- RST – right sides together.
- Seam allowance is already added.



## Materials

- 45cm strip linen (Westfalenstoffe)
- 25cm strip red and white spotted fabric
- 50cm plain ecru lining fabric
- Scraps of a turquoise floral fabric for chicken and flower
- Black thread
- 25cm x 1cm wide elastic
- Glue stick
- Water soluble marker

**To Cut** – See pattern sheet for pattern pieces

- Cut 1, 42cm x 40cm from linen for main bag
- Cut 2, 42cm x 19cm from the red and white spot for the top and bottom cuff
- Cut 1, 42cm x 40cm from the ecru for the interlining
- Cut 1, 42cm x 74cm from ecru for bag lining
- Cut 1, 12cm x 6cm from any fabric for hanging loop

## To Sew

- 1 With the wrong sides together, sew the interlining piece to the linen. This will provide a sturdier backing for when you begin to free-machine embroider.
- 2 Attach a red and white spotted panel to the longer sides (top and bottom) of the linen. With RST, pin and then sew in place. Press the seams.
- 3 Find the vertical centre line of the linen. Using the line drawing template, cut appliqué pieces from your fabric scraps and glue them into place using the glue stick. You can swap the fabrics about – if you prefer a red and white spotted chicken with floral trim, go for it!



4 Use the water soluble marker to add the line drawing elements, the word 'recycle' and draw in the chicken's legs, grass and flower stems too.

5 Embroider the drawn elements and the pieces in place using free-motion machine embroidery techniques. When you have finished, clip all of the threads close to the work and remove the water soluble marker lines with a little water.

6 Make the hanging tab by folding the 12cm x 6cm rectangle in half lengthwise. Fold the two raw edges to the centre line and press in place. Machine topstitch down each long side.

7 To make the lining, place lining with the outer bag RST, sew along both the top and bottom edges. Turn right side out. With the right side of the bag facing inwards, fold the bag in half lengthwise to form a very long tube. Insert the hanging tab 12cm from the top edge and stitch down the back seam but not across the bottom. Turn the bag right way out. Iron the top and bottom seams flat and then topstitch to make a neat edging.

8 Measure downwards 5cm from top edge and sew two rows of stitching, 2cm apart to make a channel for the elastic. Insert the elastic by unpicking a

small section in the lining and push the length of elastic through using a safety pin. Pull and tie elastic to make the bag gather, but remember to leave enough room to allow your plastic bags to be placed inside. Hand stitch the channel closed.

9 Measure 5cm up from bottom edge and repeat step 8 to make an elastic channel in the lower section of bag. (See Good To Know section for elastic tips).

## Stockist Details

Linen – [www.westfalenstoffe.co.uk](http://www.westfalenstoffe.co.uk),  
tel: 01528 522277

Name... Debbie von Grabler-Crozier

All About Me... I have been crafting as long as I can remember – my Nana first taught me to sew on her turn of the century, Singer machine and I was hooked. I also love to make quilts, paint, embroider and will try just about anything crafty...except knitting! I love working from home and my boss is my little Cocker Spaniel Sally – a wonderful little friend and my most valuable business asset.

# Home from Home!

DESIGNED BY Chris Gray



This bright yellow caravan will add a little sunshine to any room or even your own home from home! Use up fabric scraps for appliqué and simple straight stitches to add outlines and details.

## Materials

- 25cm x 25cm Calico background fabric
- Small pieces of 5 or 6 different colours of cotton fabrics – I used Spraytime by Makower UK
- Scrap of black or dark fabric for caravan wheel
- Bondaweb
- 25cm x 25cm lightweight wadding or stabiliser
- Card for templates
- Coloured pencil (for curtains)
- Soft (2B) pencil or disappearing marker pen
- Dark sewing thread for outlines
- Green sewing thread for flower stems
- 2 Small flower buttons

## Good To Know

- *Use fabrics without too much design – fabrics with a tonal pattern or texture work well for this project.*
- *I've done my piece to fit into a frame so that I can hang it up in my caravan, but the design can also be scaled-up to make cushion panels, wash bags, tea cosies or any other item that you could possibly need in your own little Home from Home!*

**To Cut** – See pattern sheet for pattern pieces



Trace pattern pieces onto some card to make templates, I used an old cereal box

## To Sew



**1** Iron Bondaweb onto the back of your fabric pieces. Draw around templates onto the paper side with a soft pencil and carefully cut out.

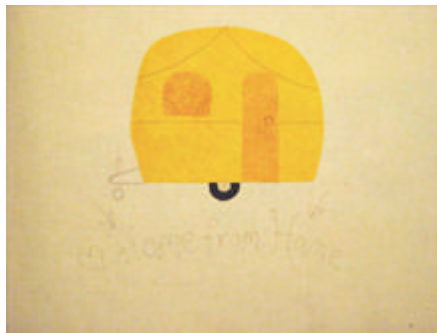

**2** Remove the backing paper, place pieces in position on the calico and iron to fix in place. Using a soft pencil or disappearing marker pen, draw in the stitching lines as per diagram.

**3** Iron a piece of Bondaweb onto the back of the background fabric, remove paper and attach wadding or stabiliser. (If you choose to use a tear-away stabiliser, then you won't need the Bondaweb here.)



**4** Thread your sewing machine with dark thread and set to a very small straight-stitch. Carefully sew over all the marked lines and around all pieces of the caravan, very close to the outer edge. I find that going over the lines twice gives a better look.



**5** Remove the backing paper from the bunting pieces and iron in place.

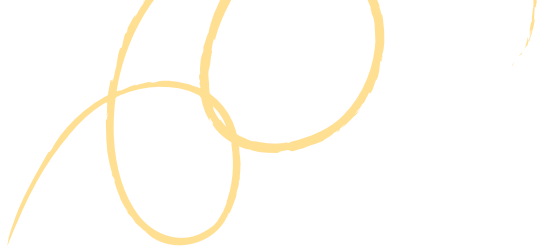

**6** Stitch the bunting flags in place; sew your line a little away from the outer edge of the triangle.

**7** Change to green thread and sew the flower stems and leaves. This stage may also be done with a free-machine embroidery method if you are more comfortable doing it that way.



**8** Colour the caravan curtains with a coloured pencil – this saves fiddling with curtain fabric! Finally attach flower buttons on top of stems.

Cut to fit your frame...and enjoy!

### Stockist Details

Calico, Bondaweb, wadding, stabiliser, threads – Empress Mills, [www.empressmills.co.uk](http://www.empressmills.co.uk)

Spraytime fabrics – Makower UK, [www.makoweruk.com](http://www.makoweruk.com)



**NEW FOREST FABRICS**

Safari Park by Lewis & Irene

Telephone: 02381 783386 Website: [www.newforestfabrics.co.uk](http://www.newforestfabrics.co.uk)  
Email: [customerservice@newforestfabrics.co.uk](mailto:customerservice@newforestfabrics.co.uk)

Fabric | Haberdashery | Craft Books | Patterns

[www.plushaddict.co.uk](http://www.plushaddict.co.uk)

Share with us @plushaddict  
#fabricgasm

**PLUSH ADDICT**  
sales@plushaddict.co.uk 0845 519 4422

**sewbox.co.uk**

On-line stockists of Liberty fabrics -  
tana lawns, needlecorde  
Lantana, jersey and Lifestyle  
Designer dressmaking patterns  
including Hot Patterns, Colette, Kwik  
Sew, Serendipity Studio, Modkid,  
Sewaholic, DIY Couture, Papercut,  
Christine Haynes and Eliza M, By  
Hand London, Sewing Cake, Gather,  
Tilly, Sew Over It & Bluegingerdoll

For amazing offers visit  
[www.sewbox.co.uk](http://www.sewbox.co.uk)

Prices start from just £99

**The Sew Studio**  
contemporary, relevant sewing instruction

**Professional Sewing Instruction**

If you are interested in contemporary, relevant sewing classes The Sew Studio is the place for you.

Exciting new location; from April classes will be held at Asha's Inspired Living in the centre of the historic town of Oundle. The Bazaar, West Street, Oundle, PE8 4EJ.

Private tuition from the comfort of your own home is also available on request.

Book online by visiting [www.thesewstudio.org](http://www.thesewstudio.org)  
or call 07725 197603 or email [contact@thesewstudio.org](mailto:contact@thesewstudio.org)

# We Meet...

## Janet Clare

Janet Clare is an artist, designer, teacher, sewer, quilter, mother, and all round creative thinker. In 2014 her book, *Home Quilt Home* was published by David & Charles and over the past few years, she self-published three books from which two she has developed fabric ranges for US fabric company Moda – *Hearty Good Wishes* and *A Field Guide*. Her work often uses soft neutral tones matched with dark inky blues and is very reminiscent of the English landscape, countryside, coastline, flora and fauna, plus notes of her vintage treasures found in local antique shops. We found out more about Janet and the studio where she works.



### Where is your main studio?

Just off my kitchen. It used to be the garage – now we have half a garage and a lovely little studio! It is filled to bursting with all my fabrics, notions and books and treasures and finds – including my china dog collection! It has four skylights and I love it.

### Who visits the studio most often?

My Betty! Particularly in the winter when the underfloor heating is on. After her it's my boys – they can often be found lying under the table or sometimes even fiddling with some sewing.

### What's the view from the main window?

Trees and sky but I have to really want to look out the window to see anything because they're in the roof! It's better that way as I spend enough time daydreaming as it is.

### What was your favourite studio buy?

The storage I guess – white, practical and large (but not large enough of course) Ikea expedit range or the under floor heating which is gorgeous in the winter!





### What hangs on the walls?

Lots of old photos I've found whilst thrifting, old embroideries and tear sheets from magazines. Inspiration hangs on my studio walls. The rest of the house is much simpler and less cluttered – my studio is completely different and just filled with good things.

### Which is your favourite sewing machine and why?

I have a Pfaff quilt expression 4 which I love because it is my loyal and hard working companion.

### What is your best tool or gadget for sewing and why?

I'm not into gadgets and tools, so I'm going to choose my Ernest Wright handmade scissors. Good old fashioned, properly made scissors that will outlast me – [www.ernestwright.co.uk](http://www.ernestwright.co.uk).





## What are your top 5 tips for organising your studio?

I really like my big storage unit (Ikea's expedite) – it's white, strong and reasonably priced too. I have some of their white baskets and some as shelves. I really prefer old baskets and tins which look lovely but maybe aren't the best use of space. I also collect jam jars and syrup tins and use those for paint and pins and pens etc.

### My top 5 tips are:

- 1 Shelves, shelves and more shelves.
- 2 I really like my rail with the 's' hooks by my machine, lots of scissors and rotary cutters and a big fat velvet '40' hang there!
- 3 A chalk board – I painted the door to the garage.
- 4 Have a major clear out and only keep notions and fabric that actually inspire you. Give everything else away – all those UFO's and fabric you bought but don't really like – it all just makes you feel guilty and weighed down. Throw it out and move on. It's liberating!
- 5 The very best thing I ever did to help with creativity and productivity is to make my artisan apron – my work uniform. I put it on when I intend to design and work and take it off when I'm finished for the day. Everyone knows (including me!) that if I'm wearing my apron I'm working. Invaluable for a stay at home mum of two boys and a big black dog, whose day could easily be swallowed by chores and not by my design work.

You can't organise clutter and mess is stress. I look more organised than I actually am – but wouldn't you if your studio was going to be in a magazine!



### Further Information

To find out more about Janet and her work, fabric collections and books, visit [www.janetclare.co.uk](http://www.janetclare.co.uk)



# WIN OUR FRIENDS in the Garden Fabric!

Your chance to WIN fabrics by British company Lewis & Irene, from their Brand NEW collection – Our Friends in the Garden

**WIN**  
We have 8  
Fabulous Forties  
fabric rolls,  
each worth  
**£30!**

The little explorer with his magnifying glass clutched in his hand is off on a minibeast hunt. Searching under logs and peeking under leaves discovering all manner of creatures. Gently collecting little friends to examine and counting all those legs! Many happy hours to be spent with...

Lewis & Irene are a British, family run business with fresh, homegrown designs printed on high quality cotton. They sell to lovely craft and fabric shops in the UK and across the world through leading distributors. For more details visit [www.lewisandirene.com](http://www.lewisandirene.com).



## Competition

For your chance to win one of eight Fabulous Forties fabric rolls worth over £30 each, simply answer the question below from this June issue of Sewing World.

Fill in the blanks – Our Friends in the \_ \_ \_ \_ \_

The winners will be the first eight entries, selected at random. Entries must be received by 30th June 2015. Don't forget you can now enter competitions online at [www.inspiretomake.com](http://www.inspiretomake.com).

**How to enter our competition:** Complete the competition coupon and send to: Lewis & Irene Competition, *Sewing World* magazine, Traplet Publications Ltd, Traplet House, Willow End Park, Blackmore Park Road, Malvern, WR13 6NN to arrive no later than **30th June 2015**. Only one entry per household – photocopies accepted. You can also fill in the coupon on our website [www.sewingworldmagazine.com](http://www.sewingworldmagazine.com).

**General rules:** The appropriate number of winners for the Lewis & Irene competition will be selected at random from entries received by the appropriate closing date. Competition winners will be notified of their success within a month of the closing date. The Judges' decision is final. No correspondence will be entered into. For full terms & conditions please refer to our website [www.inspiretomake.com](http://www.inspiretomake.com).

### Lewis & Irene Competition

to be received by 30th June 2015.

Full name: .....

Address: .....

Post code: .....

Telephone: .....

Email: .....

Answer: .....

Please tick if you do not wish to receive any information, special offers and new releases regarding Traplet products. It is the policy of Traplet Publications **not** to sell customers' details to third parties.

# Summer Florals



Cherry Polka Dot Rose Pink,  
100% cotton,  
£3.75 fat quarter

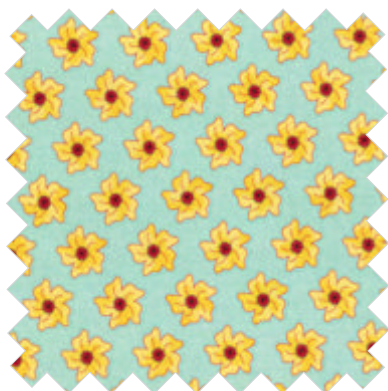

Floral Pinwheels in turquoise,  
100% cotton,  
£12 per metre



Japanese Floral Multi,  
100% cotton,  
£3.50 fat quarter



Lilly Sky,  
100% cotton,  
£3.75 fat quarter

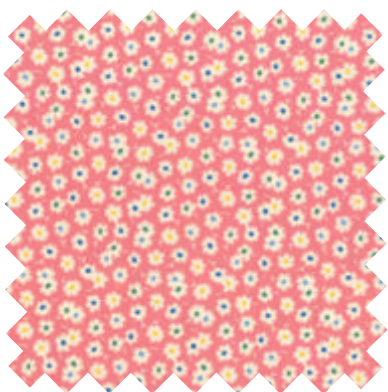

Floral Spiky Flower in pink,  
100% cotton,  
£12 per metre



Ferns Floral Turquoise Blue,  
100% cotton,  
£3.50 fat quarter

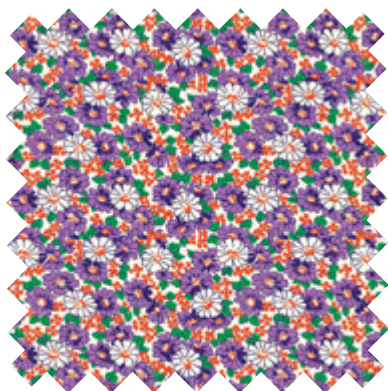

Hope Chest Purple,  
100% cotton,  
£3.50 fat quarter



Floral Straw Flower in multi,  
100% cotton,  
£12 per metre



Blooms Red,  
100% cotton,  
£3.75 fat quarter

The Homemakery,  
[www.thehomemakery.co.uk](http://www.thehomemakery.co.uk)

Plush Addict,  
[www.plushaddict.co.uk](http://www.plushaddict.co.uk),  
email: [sales@plushaddict.co.uk](mailto:sales@plushaddict.co.uk)

Elephant in my Handbag,  
[www.elephantinmyhandbag.com](http://www.elephantinmyhandbag.com),  
email: [stephanie@elephantinmyhandbag.com](mailto:stephanie@elephantinmyhandbag.com)

# A selection of blooming beautiful fabrics to inspire a summer full of fabulous floral makes!



*Yellow Flower on White*  
designed by Pamela Rinehart



*Bold Floral in red and orange,*  
100% cotton,  
£3.25 fat quarter



*Bloominescent,*  
100% cotton,  
£12 per metre



*Pink and Blue Flowers*  
designed by Maria Cherevan



*Blooming Blossom in multicolour yellow,*  
100% cotton,  
£2.99 fat quarter



*Floral Leaf Fans,*  
95% viscose 5% elastane,  
£10.80 per metre



*Creamsicle Flowers*  
designed by Virginia Oden



*Bold Floral in pink & blue,*  
100% cotton,  
£3.25 fat quarter



*Penny Rose,*  
100% cotton,  
£12 per metre

Spoonflower, designs can be printed on a variety of fabrics please visit [www.spoonflower.com](http://www.spoonflower.com) for details and pricing

My Fabric House,  
[www.myfabrichouse.co.uk](http://www.myfabrichouse.co.uk)

Fondant Fabrics,  
[www.fondantfabrics.co.uk](http://www.fondantfabrics.co.uk),  
email: [kira@fondantfabrics.co.uk](mailto:kira@fondantfabrics.co.uk)

# Masterclass Sewing Skills!

## Part 9 – Decorative edgings

WRITTEN BY Angela Venn

There are many ways of finishing the edge of fabric with a decorative trim such as piping, binding or a frill. All of the processes will add interest and texture to whatever you are making so that your finished item looks that little bit more special. The extra detail will add to the cost and time it takes to complete – but I always think that it is worth the extra effort.

You can choose to add an extra edging detail to almost anything. A cushion cover will look that more professional with piping around the edge, binding an apron with a contrast colour will make a utility item more attractive and simply adding a short fringe into a seam could create that wow factor that you've been looking for.

### Binding



There is a huge selection of readymade bindings available in different widths, fabrics and colours. From 100% cotton to linen or satin and polyester. You can buy plain, checks, floral, polka dots and even with a picot finish. Most bindings are made in three different widths – 12mm, 18mm and 25mm. You decide which one is right for you, but remember that thicker fabrics might not slot securely into a narrow binding.

Even with hundreds of bindings to choose from there will be occasions where you just can find the right one to go with your sewing project. In that instance you might decide to make your own, which isn't as difficult as it sounds. A super little gadget called a bias tape maker is readily available in a range of sizes from 8mm to 50mm, and your finished binding will be as good as readymade binding you can buy.



### To make your own binding



- Cut strips of fabric double diagonally across your fabric, double the width of the desired size.

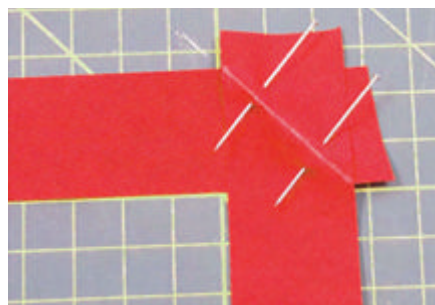

- To join several strips to create a longer continuous length of binding, place 2 strips right sides together at a 90° angle and stitch diagonally across overlap.

- Press open and trim off excess.



- Slot the end of fabric into the tape maker and pull enough through to get started.
- Ensure that each side is equally placed in the tape maker or folded edges could be lopsided.
- Press the binding with an iron as you pull the fabric through.

### To attach binding



- For a straight edge you can press your binding so that the folded edges are together. Wrap binding around cut edge and position under sewing machine foot. Hold binding in place and stitch close to the inside edge.



## Piping

Cotton or polyester cord is wrapped inside fabric to create a piping. Just like bias binding you can choose from a huge selection of plain or printed readymade piping. Making your own is a simple process if you can't find what you want, using your own fabric or readymade bias binding and cord of the desired thickness from size 1 being the thinnest, to size 6 being the thickest.



- To create a join, fold back the binding approximately 1.5cm at the start so that the binding will overlap at the finish.



- Fold the binding over the edge to wrong side of fabric and press so that the stitch line is just hidden.
- Stitch close to the inside folded edge of binding to complete process and press for a beautiful finish.

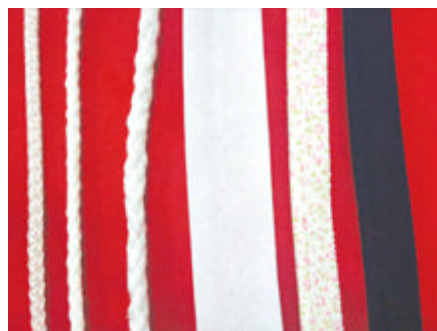

## To make piping

- Cut 4cm bias strips or press out the folds of readymade binding and loosely wrap around cord.



- You will need to change the sewing machine foot to either a zipper or piping foot to cope with the bulk.

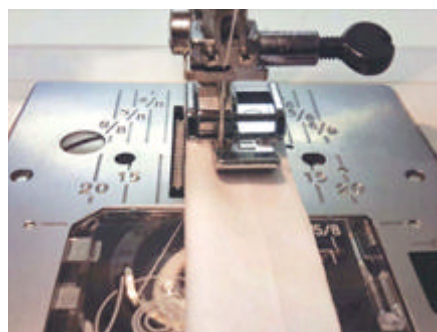

- Stitch the binding close to the cord so that fits snugly and ensuring it will not pull out of the end easily.

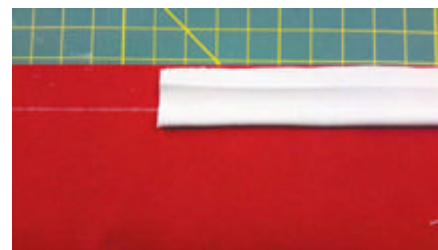

- It can be difficult to position the piping on the seam line so drawing it onto the right side of your fabric with chalk will help. The stitching on the piping must lie on top of your chalk mark.



- Position piping and pin in place, curling the start so that it runs off the edge. Sew as close to the cord as possible.



- Stop sewing approximately 8-10cm from a corner. Snip the binding edge at 1cm intervals – this will allow the binding to open and curve itself neatly around the corner.
- Bulk of the cord can cause the piping to stretch as you sew which causes puckering in the fabric. Careful handling will be needed to prevent this.

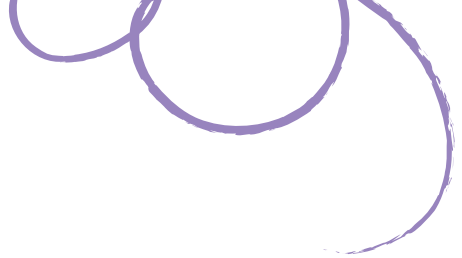

- If you are attaching piping where the end and start will meet (eg. cushion cover) – simply place the end of your binding on top of the start and curl it off towards the edge as at the start. Your sewing machine will cope with the bulk easily allowing you to sew over the binding ends and keeping your sewing in a straight line.

### Frills



In a previous skills session we covered permanent gathers. Using this technique we can create a frill which is very popular for use on soft furnishings or as a decoration around the edge of a garment. Cut strips of fabric the required frill depth, add a seam allowance and

hem allowance – the hem should be sewn before you create the gathers. For a neater finish you can fold the fabric in half, eliminating the need for a hemmed edge, but this is not suitable for heavy or thick fabrics.

### Edge frill

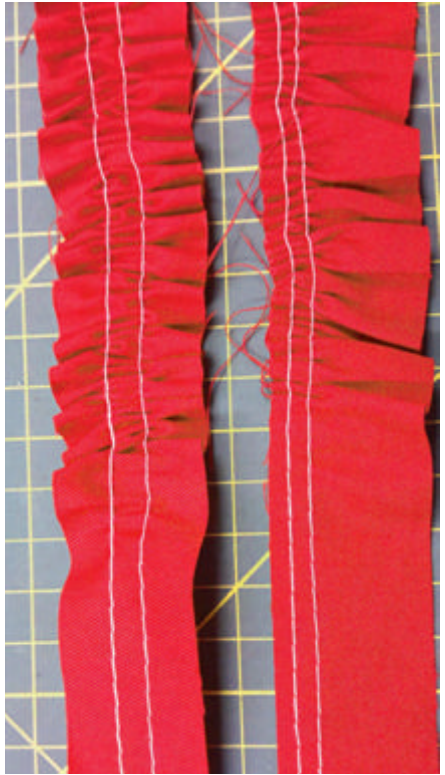

- Using a long stitch within the seam allowance, sew two straight lines and use these to gather the fabric.

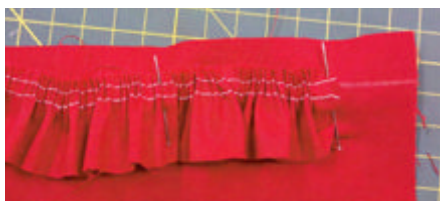

- With right sides together, pin frill to fabric edge and sew through double row of gather lines.



- If frill is being slotted between 2 layers of fabric, place on top and sew back over stitch line.



- For frills that are not going from end to end, curl frill ends towards fabric edge so that it runs off fabric, sew and cut off excess.

### Centred frill

- Hem edges on both sides of your strip.
- Using a long stitch, sew two gather lines down the centre of fabric strip and use to gather to required fullness

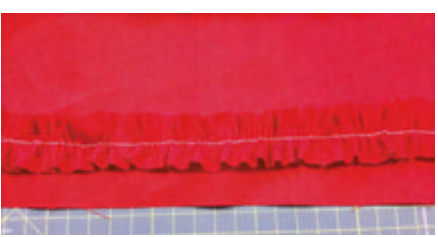

- Pin frill in position and stitch through middle of frill, removing gather threads afterwards.



## Fringing

This is often seen on the overlap edge of a kilt front, but can be used almost anywhere. It is best suited to loosely woven or heavy fabrics as they fray easily and give a bulkier look.



- Cut a length of fabric approximately 3cm wide and sew a line through middle. Using your fingers, gently pull strands off edge a few at a time. Repeat this until frill is deep enough.



- Position frill to right side of fabric and sew together. If fabric is thin you could double the fringe for extra bulk.



- Fringing can also be slotted into a seam.



Angela Venn runs the Venn School of Sewing and Tailoring Services in Cardiff. The School offers courses in design, pattern cutting, dressmaking, tailoring and interiors to suit all levels of skills. Visit [www.venntailoring.com](http://www.venntailoring.com), tel: 029 2038 8810 to find out more.

Keep every issue in pristine condition

Only **£9.95** +p&g

TO ORDER YOUR BINDERS GO ONLINE  
[www.trapletshop.com](http://www.trapletshop.com)

OR CALL THE ORDER HOTLINE ON  
01684 588599 (UK) • (+1) 217 355 2970 (USA)  
(02) 9520 0933 (AUS) • +44 (0) 1684 588599 (W/WIDE)

REF: BI-SW

HSAD.IND.BINDERS-JAN14

VISIT OUR ONLINE SHOP FOR ALL YOUR  
HABERDASHERY & SEWING ESSENTIALS.

[www.sew2go.co.uk](http://www.sew2go.co.uk)

Wide range of Sewing & Cutting Machines, Threads, Pattern Making Papers, Scissors and much much more.

Click on Sew2go for more information on products available.



[www.sewingmachinesales.co.uk](http://www.sewingmachinesales.co.uk)

219 Whitley Road, Whitley Bay, Tyne & Wear NE26 2SY England

**Sales • Parts • Embroidery software**

**Steam press • Haberdashery • Free delivery**

**24 hour on-line shopping**



**SINGER elna**  
**brother TOYOTA**  
**JANOME PFAFF**  
**Husqvarna**

**0845 430 9824**

[www.pennineoutdoor.co.uk](http://www.pennineoutdoor.co.uk)



**SPECIALIST  
OUTDOOR FABRICS**

**BY MAIL  
ORDER**

- Waterproof and breathable fabrics
- Three different weights of fleece
- Softshell, laminated fleece, Meraklon, Thinsulate,
- Heavier fabrics for rucksacs and covers etc.
- Large selection of open ended zips,
- Lycra edging tape, webbing and patterns for the outdoors.
- Seam sealants and waterproofing products.

**EXTENSIVE RANGE OF BUCKLES, HOOKS, CORDLOCKS. ETC.**

**Pennine Outdoor Ltd**

Central Buildings, Main Street, Bentham, Lancaster, LA2 7HE  
Tel: 015242 63377 • Email: [sales@pennineoutdoor.co.uk](mailto:sales@pennineoutdoor.co.uk)

# CallyCo

## Fine Fabrics and Accessories

*CallyCo has shops in Stamford and Cambridge that specialise in selling 'Fine Fabrics and Accessories'. Aimee Beard speaks to Caroline Preen to find out more about her haberdashery and interiors business.*

Caroline Preen left London in 1998 to settle in the beautiful countryside of Lincolnshire to work as an interior designer. She travelled around to meet clients and work on creating beautiful interiors, but after finding out she had a degenerative eye condition that meant she was no longer able to drive, she found herself in a tricky position regarding her career. Rather than let this stop her, Caroline, or Cally as she is known, decided that if she couldn't travel to her clients, then her clients would come to her, and so CallyCo was born.

The beautiful market town of Stamford, Lincolnshire made the ideal location for the first shop where Cally brought to life her vision of a store stocked with eye-catching and value for money dress and furnishing fabrics, haberdashery items and quirky home accessories. After a successful year of trading, and noticing a huge creative community without a local fabric shop, Cally decided to open another shop in the historic city of Cambridge and found a fantastic location just around the corner from King's College and opposite Jamie Oliver's chic restaurant.

**WRITTEN BY** Aimee Beard



This was over five years ago, in the midst of the UK recession and CallyCo has continued to go from strength to strength with both stores being warmly welcomed in each of the locations. Cally sources fabrics and items for the stores using her fantastic eye for detail, often predicting as well as reacting to current trends and responding to customer needs, whilst keeping value for money in mind. Furnishing and dress fabrics stand as the stores biggest sellers, and that's not surprising once you browse amongst the gorgeous selection of patterned and plain fabrics that range from old English, vintage charm, through French linens and tickings to modern geometrics. But the gifts and homeware also draw you in, with cute and quirky items like the London Bus Pin Cushion Kit which provides pre-cut felt pieces to make an adorable pin cushion and the ditsy floral print Owl Cushion named 'Sylvia' who would make the ideal kitsch accessory for the home.

The CallyCo staff have won awards for their exceptional customer service through a number of anonymous mystery shopper visits, proving that they are more than happy to help with any enquiry however large or small. They simply aim to make your shopping experience as enjoyable and easy as possible – 'both shops are staffed by such an amazingly dedicated team and I feel very lucky to have found them', says Cally. This happy to help customer service combined with knowledge and professional experience (everyone who works at CallyCo is a designer, maker, sewer or all three!) allows CallyCo to offer a unique Made to Order service, where customers can order custom-made interior pieces such as curtains, blinds, cushions and pin boards to whatever else they envision for their home! The CallyCo team are on hand to offer help and advice on



everything from how to measure up your windows correctly to compiling material swatches to see which fabrics work best within your home – making those dream furnishings an accessible reality.

With such a golden customer service team, CallyCo have built a very strong and loyal customer following that has enabled the business to keep on growing and evolving, and it is this creative community that inspired Cally to start running sewing courses at the Cambridge store. The workshops aim to inspire, encourage and develop all abilities with new ideas and techniques, welcoming all sewers from beginners to advanced and even the social sewer! 'Whether you want to improve your sewing technique, become more accomplished or just want to sew for yourself or family, you have come to the right place. We offer friendly, affordable classes in a specially equipped workspace in Cambridge providing a wealth of knowledge and expertise so you can get advice and inspiration, make friends and learn something new, whilst munching on biscuits and drinking tea!' says Cally.

Current classes offer a wide range of sewing challenges, from making your very own pyjama bottoms, handy storage boxes or pom pom trimmed cushions, to the more challenging workshops showing you how to make roman blinds, working with stretch fabrics and learning how to achieve the perfectly fitted tailored garment. A modern take on traditional patchwork and quilting is also offered along with a 'Sewing Surgery' where they offer advice and practical, creative solutions to those in need of help with projects, alterations and clothing revamps.





The future for CallyCo looks as bright and exciting as its stores, with a focus on continuing to develop the courses available, expanding the range of stylish yet affordable fabrics from the UK, Europe and beyond, and offering a bespoke making up service that makes a house into a unique home.

CallyCo have a website, so even if you can't make it to one of their stores, their fabrics and accessories and even advice are just a click away. Social media is an area CallyCo are really hoping to develop in the future months, in order to be able to bring their quirkiness and quality to the online creative community and allow followers to find inspiration and information on their latest fabrics, products, workshops and news.



## Further Information

To find out more about CallyCo, to buy fabric or book onto one of their workshops, visit [www.callyco.com](http://www.callyco.com) or pop into one of their shops in Stamford or Cambridge.

CallyCo – Stamford (Mon-Sat 9.30am-4.30pm, Sunday Closed)  
 5 Stamford Walk  
 Stamford  
 Lincolnshire  
 PE9 2JE  
 Tel: 01780 753409  
 Email [Stamford@CallyCo.com](mailto:Stamford@CallyCo.com)

CallyCo – Cambridge (Mon-Sat 10am-5.30pm, Sunday 11.30am-4.30pm)  
 7 Peas Hill  
 Cambridge  
 CB2 3PP  
 Tel: 01223 778744  
 Email [Cambridge@CallyCo.com](mailto:Cambridge@CallyCo.com)

HSAD.SW.BACKISS.Q1.MAR14

MISSED AN ISSUE  
OF YOUR FAVOURITE  
CRAFTING MAGAZINE?



SIMPLY GO TO  
SHOP.INSPIREDTOMAKE.COM  
AND KEEP YOUR  
COLLECTION COMPLETE

Or Call: 01684 588599; Overseas +44(0)1684 588599



Manchester



Birmingham

**1000s of Rolls  
at Realistic Prices!**

Stockists of all kinds of

- Fashion Fabrics
- Woollens
- Worsteds
- Polywools
- Polyesters
- Cotton
- Dance Wear
- Linings
- Bridal Wear
- Satins
- Suiting
- Lycras

and much, much more!

**burda**<sup>®</sup>  
Vogue  
PATTERNS

JOHN KALDOR  
NEW LOOK

Leon's Fabric Superstore  
419 Barlow Moor Rd  
Chorlton Manchester M21 8ER  
Tel 0161 881 7960

Barry's Fabric Superstore  
1 Moseley Street  
Digbeth Birmingham B5 6JX  
Tel 0121 622 6102

[www.leonsfabrics.co.uk](http://www.leonsfabrics.co.uk)

Get mobile with our **free** APP!



Now you can read  
**Sewing World**  
magazine -  
wherever you are!

Available at [pocketmags.co.uk](http://pocketmags.co.uk) for iPad • Android • Kindle Fire • Windows 8

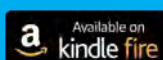

# More Brilliant Bag Making!

WRITTEN BY Susan Dunlop of SusieDDesigns

## Part 3 – Zippers

This month we take a look at how you can incorporate zips into your bag projects. Zips are perfect for adding a secure, main closure and for making handy zipped pockets. It's probably the most daunting part of bag making but, with a little bit of know-how and some practice, you'll find zips aren't too difficult to install.



## How to make a hidden zipped pocket

**1** To make a pocket with a 30cm opening, cut two 36cm wide pocket pieces from your chosen fabric. This size will be suitable for a tote bag which has a main body size of around 40cm wide. Make the height of the pocket pieces at least 10cm less than the bag's main body. Fuse suitable interfacing to the W/S of the pocket pieces.

**2** Mark a 30cm x 1cm rectangle onto the W/S of one pocket piece, 5cm down from the top edge and centrally widthways. Draw another line, centrally along the length of the rectangle, starting and stopping 5mm from the short edges of the rectangle. Draw V shapes at each end of the central line, going into each corner of the rectangle.

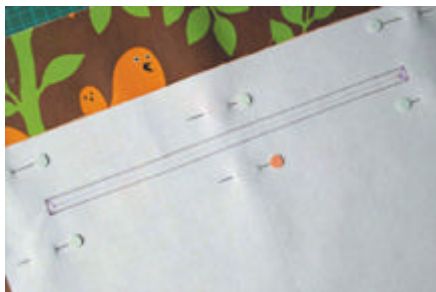

**3** Place the pocket piece centrally on top of a main body outer or lining piece, with RST, pin. Stitch through both layers, following the outer lines of the marked rectangle.



**4** Cut along the central line of the rectangle, going through all the layers. Snip into the V shape lines, going right up to the rectangle corners but not through the stitches.

Tip: Use a seam ripper to make a starting hole in the centre line before continuing with sharp scissors.



**5** Push the pocket piece edges through the opening to bring both pieces WST. Press both sides of the opening to define and neaten up the opening.



**6** Stitch together the zip-pull end of a 30cm zip with a few hand stitches. Apply double-sided sticky tape to the right side of the zip, along both long edges (optional). With both R/S up, place the main body on top of the zip, positioning the zip neatly inside the hole. Apply pressure around the opening to firmly secure the taped zip edges to the main body. Alternatively, pin and baste the zip into position.



**7** With a zip presser foot, topstitch around the zip opening, with a 3mm seam allowance.



**8** Place the other pocket piece on top of the stitched one, with RST and all edges matching. Pin the pocket edges together, holding the main body out of the way as you pin each side. Stitch all the edges of the pocket, folding the main body back and out of the way as you stitch each side of the pocket.

**9** Continue with the main bag construction.



## How to make a main closure zipper panel

**1** I used a 38cm chunky zip as an example for the following instructions. Cut a 6.5cm x 12.5cm piece of fabric to make a zip-end tab. Fuse with suitable interfacing. Fold tab in half widthways, RST, pin. Stitch the sides with a 1cm seam. Trim across the bottom corners, avoiding the stitching. Turn to R/S, pushing corners out. Fold in the raw edges by 1cm.

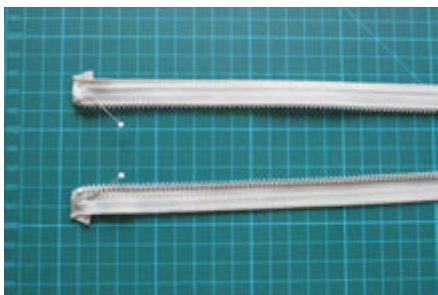
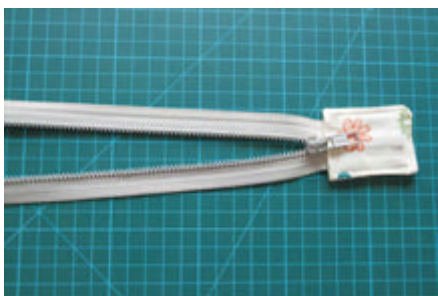

**2** Insert the closed end of the zip into tab, pin. Topstitch across tab opening, 3mm from edge. Continue to topstitch around the other three sides. Fold back the zip tape ends at angles, pin.

**3** Cut two outer and two lining zip panel pieces, measuring 8cm x 33cm (adjust the length according to the size of zip you're using). Fold the short ends of all four pieces to the W/S, by 1cm, press. Topstitch with 5mm seams.



**4** With both R/S facing up, align one long edge of the zip along the long edge of a lining piece, with the tab end extending past the short edge.

**5** Lay an outer piece on top of the lining, RST, so the zip is sandwiched between the layers. Match up all edges, pin. Hand baste, if preferred. Using a zip presser foot, stitch close to the zip teeth.



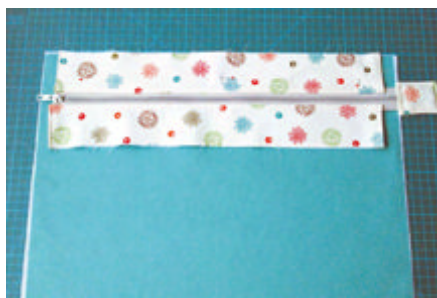

**6** Flip back both the lining and outer, to bring both WST. Match up all the edges, press and pin. Topstitch close to the edge, near the zip. Topstitch another parallel line of stitching 3mm from the first row.



**8** The zip panel can now be sewn into the main body top edge seams of the bag, during construction. Alternatively, if you're making a bag which has top panels, sew the zip panel edges between the main body and top panel seams.

**7** Repeat steps 4 to 6 to sew and topstitch the remaining zip panel pieces to the other long edge of the zip.

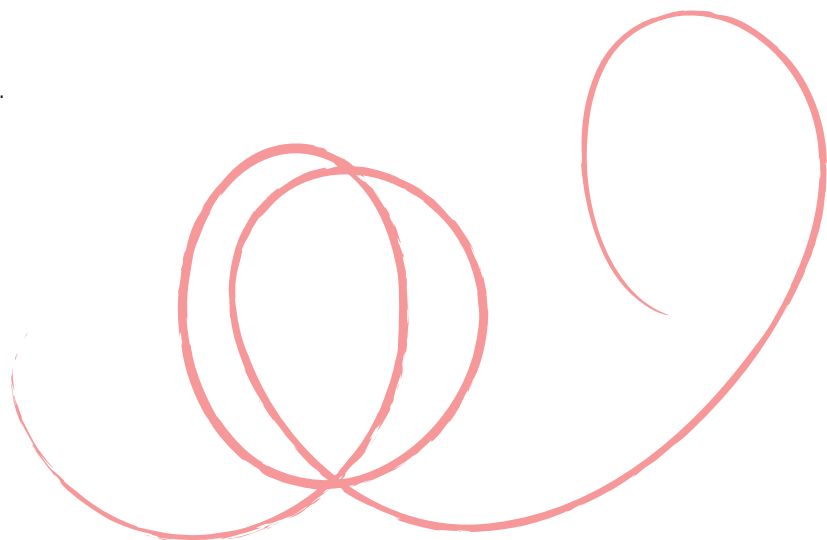

## Further Information

Fabrics illustrated in this article are from:

Michael Miller Fabrics,  
[www.michaelmillerfabrics.com](http://www.michaelmillerfabrics.com)

Moda Fabrics, [www.unitednotions.com](http://www.unitednotions.com)



**Name** Susan Dunlop

**All About Me...** I live in Scotland with my husband and four children. I love sewing, adore modern fabrics and bags are my thing. Look out for my new bag-making book, *Style and Swing: 12 Structured Handbags for Beginners and Beyond*. Visit [www.susiedesigns.co.uk](http://www.susiedesigns.co.uk) for patterns, supplies and kits.

# CREATIVE CLIPPINGS

## All At Sea!

Prepare to set sail with a fab selection of nautical themed inspirations!



Laura Strutt



This Misses' sportswear pattern features a classic knit crew neck top with long sleeves teamed here with a plunging v neck dress. Create your own sea fairing capsule wardrobe – including tunic, open front jacket and elegant trousers. Simplicity 1325, in sizes 6-22, £8.15, [www.simplicitynewlook.com](http://www.simplicitynewlook.com)



Handmade Wish List – Navy & White Chevron Fabric Headband, £8.30 from The Ocean Blue Co on [www.etsy.com](http://www.etsy.com)



Handmade Wish List – Anchor Tote Bag, £11.06 from Bonjour Teaspoon on [www.etsy.com](http://www.etsy.com)



Nautical Beauty Bag Set, £19.99 [www.oakroomshop.co.uk](http://www.oakroomshop.co.uk)



BeachHarbour Nautical Baskets, £35.00, [www.houseoffraser.co.uk](http://www.houseoffraser.co.uk)



June Must Haves...  
Docklands Cushions,  
single cushions  
priced from £9,  
[www.diy.com](http://www.diy.com)



June Must Haves...Bigger Boat Limited Edition Silk  
Screen Print, £35.00, [www.mengsel.com](http://www.mengsel.com)



Nautical Rope Frame,  
from £7.00,  
[www.tch.net](http://www.tch.net)

Laura Strutt is a keen stitcher and author of *The Sewing Manual* (Haynes 2013, £21.99) and *The DIY Wedding Manual* (Haynes 2014, £18.99) and *Arm & Finger Knitting*



June Must Haves...Patella Shell Candles,  
£21.00 for set of three, [www.in-spaces.com](http://www.in-spaces.com)

All prices correct at time of going to press

Inspired  
to make

the home of...

beads  
& beyond

CRAFT

stamper <sup>Fabrications</sup> Quilting  
for you

British  
PATCHWORK  
& QUILTING

sewing  
WORLD

Made by me...

Share your own creations with our craft community using the 'Made By Me' Feature. A chance for you to upload your makes and share them with the Inspired to Make Community.



It's as easy as the click of a mouse!

Once you have checked out the fantastic projects on Inspired to Make, keep a look out for great deals and offers on books, DVD's, Patterns and accessories all in one place in the Inspired to Make Shop – [shop.inspiredtomake.com](http://shop.inspiredtomake.com)

It's also the perfect place to get your favourite magazines (with free P&P on current issues\*) and check out the hottest subscription deals.



[inspiredtomake.com](http://inspiredtomake.com)  
[shop.inspiredtomake.com](http://shop.inspiredtomake.com)

\*UK ONLY

# Siesta

www.siestaframes.com

## Large Clip-on Magnifier

This handy magnifier can be clamped to frames, table tops and desks. The 46cm (18 inches) arm for longer reach combines with a 13cm (5 inches) lens with x1.75 magnification.

Price £25.00 Code CM1



## Sonata Seat Stand

A versatile, fully adjustable sit upon stand. Holds hoops, Bar Frames and roller frames up to 12". Features include 360° rotation, quick flip top and height adjustment. Frame as shown not included.

Price £19.98 Code SONATA



## StitchSmart Floor Stand

This stand has a unique swivel system allowing 360° rotation.

Height and working angle are adjustable. Available as a complete unit with stand, LED light-magnifier and chart clamp, or just the stand on its own.

Stand with LED light-magnifier and chart clamp £149.99 Code D24047 & D25020

£79.99 Stand only Code: D53047

Wooden frame as shown is NOT included



## Tilt Floor Stand

Flexi floor standing tapestry stand with knee joints

WTF24 Tilt Stand 24" £59.95  
WTF27 Tilt Stand 27" £61.95  
WTF30 Tilt Stand 30" £63.95  
WTF36 Tilt Stand 36" £65.95  
WTF42 Tilt Stand 42" £68.95



## LAPMAN

The frame and stand simply folds into the carry case.

Comes with a handle shoulder strap and wingnut tightener.

12" Lapman (green case) £45.99 Code LAPM/1  
15" Lapman (burgundy case) £49.99 Code LAPM15/1  
18" Lapman (blue case) £54.95 Code LAPM18/1



P&P  
£4.95  
on all orders

## StitchMaster Lap Stand

The frame simply rests on the two arms of the lap stand and holds frames up to 21". Height and angle are adjustable. (Frame as shown not included). Price £29.99 Code SMLAP



## Ultimate Floor Lamp Antique Colour

A multi-purpose sewing/craft/reading lamp with magnifier and chart holder. The lamp is height adjustable with a 20W energy saving daylight bulb.

Price £159.99 Code D21098



## Hammerhead Craft Lights

LED craft lights with base and clip. 6 bright white LEDs. 3 AAA batteries included.

Price £22.95 Codes

64821 Blue 64824 Green 64826 Pink



Available from your local stockist or from Siesta at:  
Siesta Frames Ltd., Unit D, Longmeadow Ind. Est.,  
Three Legged Cross, Wimborne, Dorset BH21 6RD  
Tel/Fax 01202 813363, www.siestaframes.com  
Other products available at www.coleshillaccessories.co.uk

# Re-fashion!

## Getting more wear from your wardrobe

### Part 3 – Collars

WRITTEN BY Wendy Ward



#### You will need:

- Small scissors with a sharp point
- Quick unpick/seam ripper
- Pins
- Matching thread
- Contrast tacking thread
- Chalk
- Fabric and interfacing – if you want to make a new collar

#### Adding, removing or changing collars on a garment can drastically change the look of it

This month I'm going to show you how to remove a collar from an existing garment to make it collarless, how to swap collars between garments and how to make a new collar. I'm using the example of some basic men's denim shirts, but the same method applies to any garment.

#### Tips before you start:

- Take your time and unpick things carefully, especially on older garments. If you get impatient and try to rip stitches out you may find the fabric ripping too.
- If you're going to make a new collar – choose a fabric that is a similar thickness and drape to the original fabric.
- If you're making a new collar and want to change the size or shape of it, make sure you don't alter the length of the inner or neck edge of the collar or it won't fit back onto your garment!

## Removing a collar & making a collarless shirt



**1** Using your unpicker, unpick the seam line along the top of the stand which is holding the collar in place. On most shirts you will find two lots of stitching to unpick along this edge – the topstitching and the actual seam. Don't unpick the whole of the seam, just along the collar edge and 1cm beyond each end so that you can easily remove the collar.



**2** You are now just left with the stand part of the collar which is open along the top edge.

**3** Pin the open seam back together and tack in place following the original seam line which will still be visible.

**4** Machine carefully and try to match the original stitch length and thread colour.



**5** Ta-dah – your new granddad collar!

## Swapping a collar



Here are the shirts I started out with – a nice pair of a dark and light denim shirts, both with the same neck size!

**1** Remove the collars from both garments following step 1 in Removing a collar.



**2** Fold the collar in half and place a pin to mark the centre – this is the centre back of the collar.



**3** Fold the neck of the garment in half, lining up the shoulders and place a pin to mark the centre – this is the centre back of the neck.



**4** Slot the raw edge of the collar into the open top edge of the stand on the neck of the garment matching up the pins.

Tip: If the fabric on the collar from the old garment is worn along the inside neck as mine was (that's the drawback of working with old shirts!) – turn it over so that the under-collar (which sat on the underside of the old collar and will be less worn) becomes the visible top collar.



**5** Carefully pin in place, trying to match up the original seam-lines, they should fit together perfectly if both your garments are the same size. Tack securely in place, again along the original seam-line. Machine stitch, trying to match the original stitch length and thread colour.



**6** Ta-dah – contrast collars!

## Making a new collar

**1** Remove the existing collar as in step 1 of Removing a collar.



**2** You can use this collar to make a collar pattern – draw around the outer edge of the collar accurately. Remove the collar and add seam allowance to the top and sides (the bottom edge where it was previously attached to the garment already has a seam allowance).

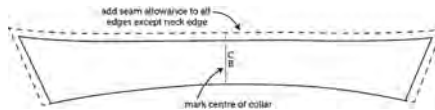

**3** Mark the centre of the collar along the neck edge.

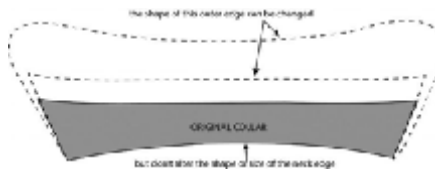

**4** You can change the shape of the outer edge of the collar to make a different style of collar, but don't alter the shape or size of the inside, or neck edge or it won't fit back onto your garment!

**5** Cut your new collar pattern twice from fabric and once from interfacing. The interfacing is attached only to the under collar.

**6** Put your two new collar pieces right sides together and join along the top edge and the sides but not the neck edge. Trim any corners and snip into any curves. Turn right side out, press well and top stitch if you want to. Attach to your garment as in step 6 of Swapping a collar.

Next month we'll be looking at swapping and changing sleeves.

Name... Wendy Ward

All About Me... I have my own business called MIY Workshop in Brighton where I teach sewing, dressmaking and pattern cutting. I am a qualified teacher, have a degree in fashion and spent 7 years working in the fashion industry before starting to teach in 2007. My first dressmaking book 'The Beginner's Guide to Dressmaking' is available now. I also design my own range of sewing patterns called MIY Collection.  
[www.wendyward.co.uk](http://www.wendyward.co.uk)  
[www.miycollection.com](http://www.miycollection.com)



Europe's leading patchwork and quilting show

# The Festival of Quilts 2015

6th–9th August

Halls 7, 8 & 9 | NEC, Birmingham, England

A celebration of quilting with over 300 exhibitors offering essential supplies, extraordinary galleries from international artists and nearly 1,000 competition quilts

For more information call: +44 (0)1473 321 872

[www.thefestivalofquilts.co.uk](http://www.thefestivalofquilts.co.uk)

Workshops and Lectures in association with



by GROVES

Image: Zsofi Atkins, Spring (detail)

# Take a course or workshop in

June - August 2015

## North

### Grace and Favour Sewing Sanctuary School

Thornton-Cleveleys, Lancashire, FY5 4JZ

[www.grace-favour.co.uk](http://www.grace-favour.co.uk)

Grace and Favour has been said to be the North West's prettiest fabric shop and Sewing School combined. You can learn beginners sewing, free machine embroidery, dressmaking and lots of their craft in a fun and friendly environment. If you're not sure which crafty courses to choose then give us a call or pop into our shop for a chat and some friendly advice. They also run junior workshops aimed to teach younger students how to use a machine from the age of 8 years upwards.



#### Frilly Nappy Cover workshop 28th June 2015, 10am – 3pm

Join this fabulously frilly workshop to make cute baby nappy covers. You make plain ones, patterned ones or go traditional with broderie anglais, whatever you choose the end result is always gorgeous. During this course you will not only learn how to make a fabulous frilly nappy cover, you will

also learn lots of skills that can be adapted to any dressmaking pattern. You will also leave with a frilly nappy cover and your copy of the pattern to make as many more as you like. Skill Level 3, £19.00.

#### Appliqué art wall hanging – Use up your scraps! 4th July 2015, 10am – 3pm

Use your scraps to make stunning appliqué art. This workshop is friendly and informal so that you can unleash your creative side and develop your artistic nature. Use colours and shapes of fabric to create these wonderful masterpieces – G&F can provide fabric scraps on the day or you can bring your own to work memories and old clothing into your art work. Skill level 2, £35.



## South

### West Dean College

Chichester, West Sussex, PO18 0QZ

[www.westdean.org.uk](http://www.westdean.org.uk)

Join the annual West Dean College Summer School and spend time learning a new skill, or enhancing an existing one. This year's programme will feature 28 creative art and craft courses, including screen-printing, hand and machine embroidery, sewing and quilting, dressmaking, silk painting, tapestry weaving, lace making, hand knitting or crochet, leatherwork and are taught by professional tutors - all experts in their field. Their courses are often span a couple of days or over a weekend and so you really get the opportunity to immerse yourself and be inspired by the beautiful location, architecture and award-winning gardens at West Dean. West Dean also offers accommodation so you can take a dip their the open air swimming pool, or enjoy a spot of croquet on the college lawns.



#### Corset making from historic patterns with Fleur Oakes 17 – 20th June 2015

Learn how to adapt historic corset patterns to the modern body using the reeds and hand stitching methods of the 16th and 17th century. Examine later methods using steel boning as you make samples for future projects. Previous sewing experience is necessary. Intermediate, £372.

#### Soft leather bags and accessories with Katherine Pogson 30th August – 2nd September 2015

Sew leather by machine and hand and explore surface decoration techniques including embroidery, appliqué and studwork for making purses, bags, belts or panels to incorporate into small bags or fashion garments. Suitable for all, £322.



# your area and learn something new!

## East

### The School of Sewing with Alison Smith MBE

Ashby de la Zouch, Leicestershire, LE65 1AH

[www.schoolofsewing.co.uk](http://www.schoolofsewing.co.uk)

The School of Sewing is based in Ashby de la Zouch, Leicestershire at the heart of the National Forest. Alison, author of *The Sewing Book* and *Dressmaking – The Complete Step by Step Guide*, offers one, two and three day workshops on all aspects of dressmaking, tailoring, couture and corsetry. City & Guilds qualifications Level 2 are also available. The 2015 schedule sees workshops with an emphasis on Couture, Fit and Tailoring.



#### Wardrobe Basics 3 – Shirts, Blouses and Tops

10th & 11th June 2015, 10am – 4pm

On this two day workshop you will make a shirt or blouse or top to fit you. After adjusting the pattern, you will make your chosen garment in a fabric of your own choice, which could be a woven or a stretch knit. Learn all the tricks of the trade to turn a shirt collar, place a ruffle onto a blouse or insert a sleeve. Bring your patterns and fabric, calico will be available to purchase on the day. £240.

#### Wardrobe Basics 2 – The Day Dress with Alison Smith

19th & 20th August 2015, 10am – 4pm

A classic lined dress is a must for any wardrobe, it can be dressed up or down, worn under a jacket or cardigan or on its own. Your choice of dress pattern will be fitted, prior to construction and you will learn plenty of tricks of the trade for fit and construction techniques and hem applications. Patterns and fabric are required for this class – full details will be sent to you on booking. £240.



## West

### American Museum in Britain

Claverton Manor, Bath, BA2 7BD

[www.americanmuseum.org](http://www.americanmuseum.org)

The American Museum in Bath takes you on a journey through the history of America, from its early settlers to the twentieth century. It has a remarkable collection of folk and decorative arts and some wonderful quilts to inspire your creativity. The Museum is located in an area of outstanding natural beauty, with spectacular views over the Limpley Stoke Valley and the River Avon. It runs workshops, talks and events, often relating to their current exhibitions.

#### Embroidered Posies

27th June 2105, 10am – 4pm

Join Heart Space Studio's Janet Haigh and learn the art of ribbon-work, using simple hand embroidery skills to create 3-D flowers. Use hand-dyed silk ribbons, beads, and embroidery threads to create early summer blooms for a variety of different applications. £50 (£45 Museum members).



#### Workshop: Victorian Corsets

6th & 7th June, 10am- 4pm

Join Lisa Keating, bespoke bridal wear designer, and learn to design, cut and make a fully fitted, steel-boned Victorian corset. Based on historic patterns, these beautiful corsets can be worn as outer or under garments. £150 (£135 Museum members) for both days, plus £50 materials fee to be paid on the day.



For more details on the courses listed and to book, please visit the course providers own website

# Pattern Roundup



*Burda 6756*

Modern twist on the classics – this pattern puts a contemporary spin on classic shapes with two fashionable dress styles. Our favourite is the easy-to-wear A-line swing skirt dress cut on the bias. The other dress option is a narrow shift that is perfect for stylish colour blocking. Fits sizes 8-18, £5.85



*Burda 6774*

Wear and flare, Burda 6774 is a wonderful pattern pack if you're looking for feminine coordinates. It contains an unlined jacket with shawl collar that is as comfortable as a cardigan, plus a soft draping vest top. However, the main pull of this pattern is a pair of wide-legged trousers that is a must-make for this season. Pattern is available in sizes 8-18, £6.85.



*Hot Patterns 1170 Fast & Fabulous Blouse-Back T*

A fresh take on the classic T, this super-wearable top is designed for light to medium weight 'drapey' knits with a little stretch. The (contrast) back is gathered onto the yoke and finishes with a narrow-hemmed shirt-tail. Fast to make up, casual and feminine. A summer must have. Advanced beginner. Pattern available in US sizes 6-26, £12.95



*Bluegingerdoll Mae Blouse*

Mae is a romantic 1940s inspired blouse. Featuring a flattering scalloped front neckline, kimono sleeves and front and back waist darts. Suitable for a variety of fabrics – wear tucked in or out, Mae takes you from day to night. A button down back finishes off this lovely blouse. Beginner level. Pattern available in bust size 31-45, £13.50



*Christine Haynes Derby Dress*

The Derby Dress is a fun swiny A-line dress. Both versions are pull on and feature princess seams in the front and four panels in the back. Suitable for lightweight woven fabrics – cotton, lawn, poplin, silk, linen. Easy to make up, beginner level. Pattern available in UK approx. sizing 4-22, £15



*New Look 6344*

A pack of tops with inverted pleats at neckline. Can be sleeveless with lace shoulder detail or short sleeves with a collar. Pattern available in sizes 8-20, £5.95

# Take your pick from this great selection of new patterns!



*Simplicity 1421*

A classic unlined jacket can be made with or without collar and has separate pattern pieces for A, B, C, D cup sizes. Jacket can be made with addition of bias tape trim for an extra smart detail. Pattern available in sizes 6-24, £8.15



*Butterick B6183*

This Misses' top and pants combination is summer smart by Lisette. The semi-fitted pullover top has princess seams and exposed back zipper and the slightly flared pants are mid-length and feature side front pockets. Pattern available in sizes 6-22, £7.50



*Vogue V9047*

Close-fitting, pullover dress has bodice with raised waist, stitched hems, topstitching and sleeve/sleeveless option. From Very Easy Vogue collection, pattern available in sizes 8-24, £12



*New Look 6341*

This Misses' dress with princess seams and scoop back is perfect for any occasion. Dress can be just above the knee with or without lace sleeves, floor length with short sleeves, or sleeveless with floor length high low hemline. Pattern available in sizes 6-18, £5.95



*McCall's M7119*

The wrap dress has a fitted bodice, gathered back neckline, tie ends and semi-fitted skirt, gathered sleeve cap and shaped hem with length variations. Pattern available in sizes 6-22, £8.75

**READER OFFER**  
 We are delighted to offer readers of Sewing World, New Look pattern 6341 at a special discounted price of £2.95 – which is less than half normal price! To redeem this offer, visit [www.simplicitynewlook.com](http://www.simplicitynewlook.com) and quote SW6341 when checking out your order (p&p is 85p). Closing date 18 June 2015.  
**READER OFFER**

## Stockist Details

- THE PATTERN PAGES**  
[www.thepatternpages.com](http://www.thepatternpages.com)
- Burda patterns available from The Pattern Pages, [www.thepatternpages.com](http://www.thepatternpages.com)
- sewbox.co.uk™**
- Sewaholic and Hot Patterns available from Sewbox, [www.sewbox.co.uk](http://www.sewbox.co.uk)
- Simplicity NEWLOOK**
- Simplicity and New Look patterns available from [www.simplicitynewlook.com](http://www.simplicitynewlook.com)
- Vogue, Butterick and McCall's patterns available from Sew Direct, [www.sewdirect.com](http://www.sewdirect.com)

# BRAND NEW BOOKAZINE

Brought to you by the Sewing World team, a beautiful special issue bookazine full of your favourite projects.

Full of step-by-step projects with beautiful pictures, along with a full size pattern sheet. Each project has full, in-depth, easy to follow instructions.

## Projects include

- Bags for all uses
- Home Wares
- Kitchen Makes
- Sewing Accessories
- Toys
- Gifts

Order this beautiful brand new bookazine now!

Product Code SWSP15  
Only £7.99 + P&P/S&H



Phone our friendly customer service team on 01684 588599  
or visit [shop.inspiredtomake.com](http://shop.inspiredtomake.com)

# NEW DVD *Make it Special* RAZZLE-DAZZLE QUILT

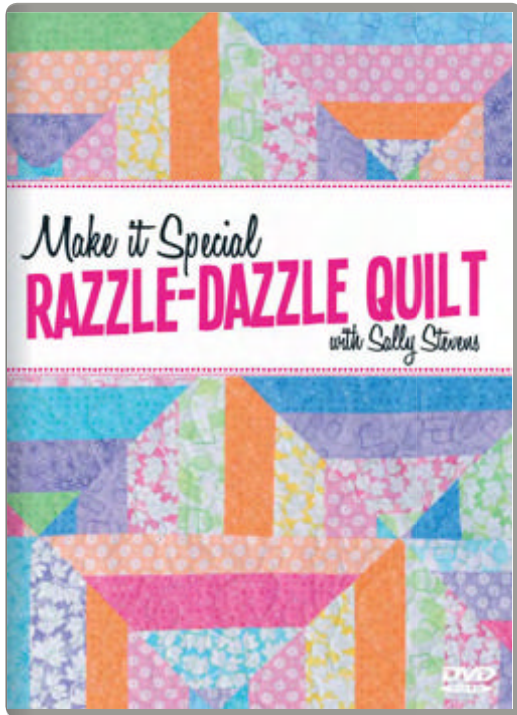

The Make It Special series of quilt making programmes aims to bring you an easy-to-follow guide to making beautiful and unique quilted products. In Razzle-Dazzle Quilt we join a workshop run by Sally Stevens, editor of Fabrications - Quilting for You magazine to make a quilt that is versatile, quick and easy to sew, uses inexpensive ScrapBag fabrics and yet looks stunning.

Sally is joined in the workshop by Lynne, Sadie, Sara and Eleanor, all experienced quilters in their own right, who each share hints, tips and how-to's along the way, whilst sharing the pleasure and satisfaction they get from their craft. Hand-made quilts make beautiful gifts for family and friends, but perhaps the greatest satisfaction that these quilters get is from donating their work to Project Linus, an organisation that aims to provide a sense of security and comfort to sick and traumatised babies, children and teenagers through providing home-made patchwork quilts and blankets for them to keep. To the recipients of these quilts each one truly is unique and something very special.

The simplicity of the Razzle-Dazzle quilt makes it suitable for quilters of all abilities, so join Sally and her team and find out just how easy it is. You too can Make it Special!



DVD Ref: DV720

£12.95 + P&P/S&H

BLU-RAY Ref: DV720HD

£14.95 + P&P/S&H

Available to Stream/Download  
Only £9.95



+44 (0) 1684 588599



[shop.inspiredtomake.com](http://shop.inspiredtomake.com)

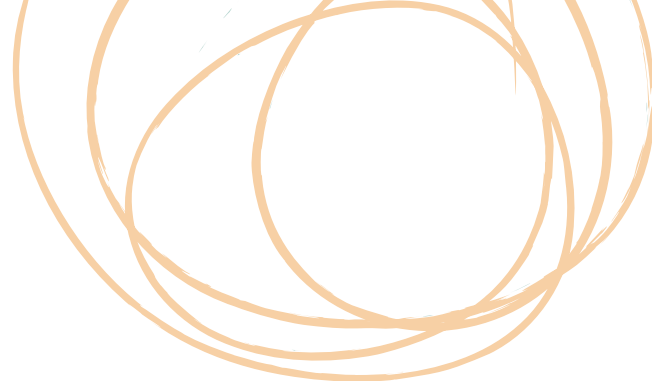

## Upstyle Your Windows

Hannah Stanton

ISBN 9781845436032

Combining clear, accessible tutorials with practical advice on choosing, styling and sewing fabrics – Upstyle Your Windows is a must-have guide for all creative homemakers and design-savvy DIY-ers looking to customise their windows with their own distinctive style. Emphasising the notion that anyone can make their own curtains, drapes, or blinds, Upstyle Your Windows has a fresh, sophisticated aesthetic and features the latest contemporary styles in window treatments – making it a far cry from the dry instructions and dated fashions found in many other books on the subject. Beautifully illustrated tutorials cover a wide range of techniques that arm readers with the skills to tackle their own projects, whether looking to make cute café curtains or stylish roman blinds. Packed with measuring tips and tutorials, Upstyle Your Windows also includes a number of engaging case studies that provide a valuable insight into the various challenges faced by other non-professionals, encouraging you take the plunge and have a go!



### Offer!

This title is published by Apple Press and is priced at £14.99. To purchase for £10 including p&p please Tel: 01903 828503 and quote reader offer code: APG320.



# bookshelf

## Reclaimed Textiles

Kim Thittichai

ISBN 9781849941280

Leading textile artist Kim Thittichai uses this book to encourage you to see new life in everything and demonstrates how to re-purpose discarded materials and packaging to create new stunning artworks and functional items. Kim takes you through a range of techniques, from collage, quilting, patchwork, rag-rugging, piecing and stitch and gives it all her own twist. Each chapter has a step-by-step finished project to help you get started and also lots of techniques and combinations for the more experienced. From reclaiming old newspapers and using heat tools to make brooches to recycling old jumpers to make new bags or reinventing old socks to create an army of eclectic monkeys and pigs, this is an innovative book on cutting-edge reclaimed textile work and it showcases some amazing work by the best students and artists working in textiles today.

This title is published by Batsford and is priced at £19.99





## Sew Fab

Lesley Ware

ISBN 9781780674049

Sew Fab is the ultimate style and sewing workbook for fashion-obsessed girls aged 8-13 years, who after reading this book will have learnt all they need to know to sew their very own unique wardrobe to suit their own style. The book begins by helping the reader choose their 'style tribe', teaching them how to identify their fashion family by what shoes they wear and then goes on to teach the young fashionista how to pick colours to suit their skin tone, which prints work well when worn together and how to choose the right accessories in order to 'live sparkly'. With the foundations covered, the book then provides advice on how to create a mini studio in which to start sewing and make some 'Art to Wear'. There's a mix of easy step-by-step projects to sew by hand or using simple machining from a hair bow, simple leggings to that must have little black dress (but in the colour that suits you best!). Packed with gorgeous illustrations, step-by-step projects, tips and fun activities, this is the perfect book to get that little designer creating unique clothes and accessories in no time.



### Offer!

This title is published by Laurence King Publishing and is priced at £12.95. To purchase with 25% off and free UK p&p please visit [www.laurenceking.com](http://www.laurenceking.com) and quote offer code: FABWORLD

## Modern Rainbow

Rebecca Bryan

ISBN 978-1-61745-018-1

What a riot of colour this book is! It's certainly one that will appeal to the modern quilter. Vibrant pops of colour are paired with neutral 'low volume' backgrounds to create 14 stunning quilt designs inspired by the colour wheel. The book starts with a very useful section on colour theory and choosing fabrics to customise your own personal rainbow and all the basic techniques you will need for constructing the projects. The quilt designs are reasonably challenging with the use of templates and multiple seam piecing and many would require some level of experience with patchwork before starting. Oh, but the beauty of the finished designs wants to make you jump right in!



This title is published by Stash Books and is priced at £17.99



## The Great British Sewing Bee – Fashion with Fabric

Claire-Louise Hardie

ISBN 978-1-84949-545-5

Published to coincide with the third series of the popular 'The Great British Sewing Bee', this book really takes a close look at the fabrics that you can use to create your own garments. The first part of the book guides the reader through the common skills needed for sewing and also how to work with patterns to get a great fit. It then launches into fabric types and 30 garments you can sew with cottons, wools, stretch and luxury fabrics. The book comes complete with five full-sized pattern sheets in a separate slipcase for you to trace off as desired and a few of the garments only require rectangles of fabric rather than a pattern. It is pleasing to see a book with sizes ranging from size 8 to size 20, making it appeal to a broader cross-section of sewers. The projects are modern and will appeal to all members of the family, including an elephant costume and that infamous kilt project for you to make for your man!



This title is published by Quadrille Publishing Ltd and is priced at £25.00

# Ready...

# Get Set... Sew!

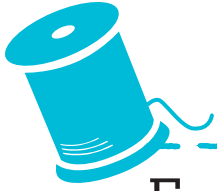

Ensure sewing success with our sewing guide to get you started, or refresh your memory...

## Using your Full-Size Pattern Sheet

**1** For projects with a pattern, first look at the glossary on the pattern sheet to identify the colour of the pieces for your project. Looking at the 'To Cut' list and the layout guide (if applicable) you will see how many pieces there are to find. Each piece is labelled and identified e.g. '1 of 7', '2 of 7' etc. It may be helpful to follow the pieces using your finger and then highlight each piece around the edge with a highlighter marker.

**2** Some larger pieces are split in two but there will always be a clear dashed join line for you to match up with the other half.

**3** Take some large sheets of thin paper or a roll of greaseproof paper and simply trace out your pieces with a fine black pen (for your size if making clothing), taking care to mark all the notches, dots and darts and join pieces up if necessary. Cut out your pieces in fabric and sew away!

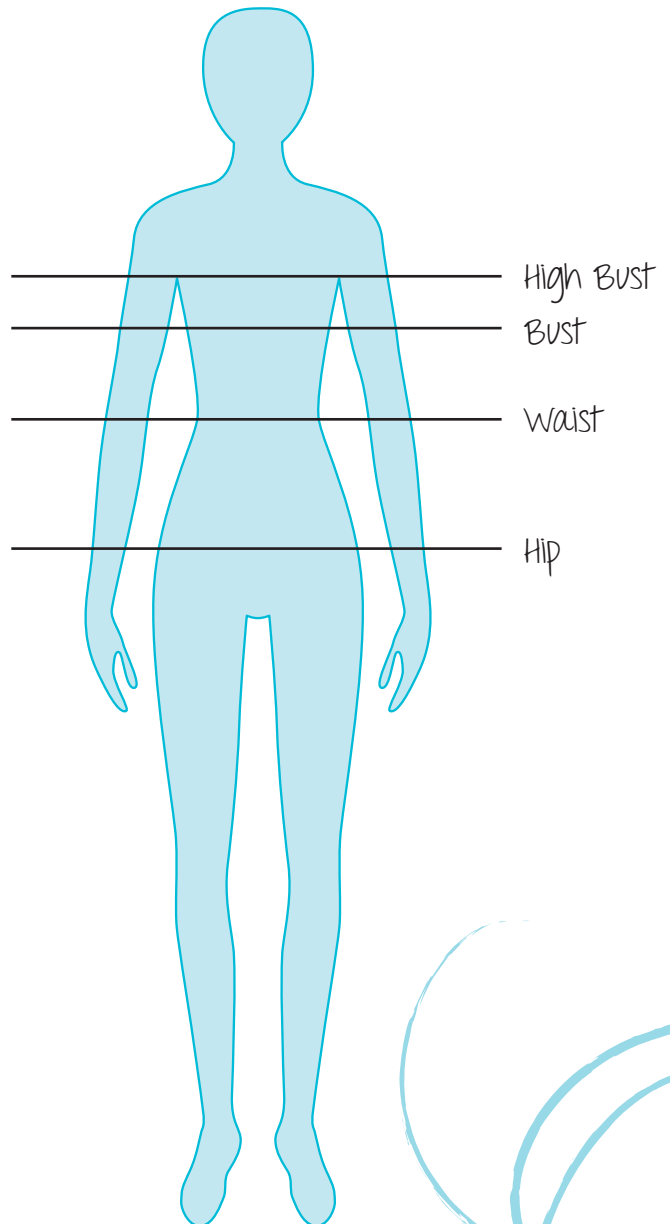

## Check your Size

Take your measurements and compare with our project sizing charts, making sure your tape measure is straight as you go around your back – best to get a friend to help!

If you fall between two sizes, make the larger size for a more comfortable fit. We suggest making a toile from calico if the garment is more fitted in style.

- **High Bust** – Above the fullest part of your bust and just under your arms.
- **Bust** – Straight across your full bust and around your back.
- **Waist** – Where your body naturally curves in.
- **Hip** – Around your hips at the widest point and the fullest part of your bottom.



## Fabric Terminology

**Selvedge** – Finished straight edge of the fabric, often printed with the manufacturer’s name.

**Grain line** – This is normally marked on pattern pieces as a double-headed arrow and should be parallel to the selvedge, or the bias if a bias-cut project.

**Bias** – Line of fabric at 45° to the straight edge, which gives a bit of stretch if pulled.

**Nap** – Fabrics with an obvious pile (nap) where the direction of the pile needs to be kept the same when making your project.

**Fat Quarter** – Quilting term for a piece of fabric cut from a 44" wide bolt measuring 1/2yd and then cut across the width at 22".

(It is recommended that fabrics are pre-shrunk before sewing, by washing at recommended temperature, drying and pressing thoroughly).

## Glossary

Some useful terms used in Sewing World...

 **Basting (Tacking)** – Temporary large stitches to hold pieces together.

 **Seam allowance** – These will be included in the pattern pieces unless otherwise stated and will vary between projects. Check carefully in ‘Good to Know’ to ensure success.

 **Pressing** – Not ironing, pressing is the action of pressing the iron onto fabric and then lifting without moving around. It helps to set stitches so that seams lie flat and crisp. Don't skimp on pressing!

 **Finger Press** – Literally a light crease with your fingernail.

 **Stabiliser** – Interfacing or interlining used to give some stability and strength to your fabric, it can be sewn-in or ironed on.

 **Topstitch** – Neat straight stitches on the right side of the fabric to define a seam.

 **Staystitch** – A line of stitching to keep curves and bias edges from stretching.

 **Understitch** – Stitched row to prevent a facing from rolling to the outer part of the project.

 **WOF (Width of Fabric)** – Across the width, selvedge to selvedge.

# giveaway

Please tick your choices – CLOSING DATE 31 June 2015

- Send to: Sewing World Giveaways, Traplet Publications, Willow End Park, Blackmore Park Road, Welland, WR13 6NN.
- Visit [www.sewingworldmagazine.com](http://www.sewingworldmagazine.com) and fill out the online form.

One entry per household – photocopies are accepted.

- Upstyle Your Windows
- Reclaimed Textiles
- Sew Fab
- Floral covered buttons

Please tick here if you do not wish to receive any information regarding Traplet products. (NB: It is the policy of Traplet Publications not to sell on customers' details to any third parties, except for notification of prize winners as necessary)

I am a current subscriber

Name: .....

Address: .....

Post Code: ..... Tel: .....

Email: .....

We would appreciate your views on this particular issue. Please also complete the questions below:

Favourite article: .....

Least favourite article/feature this month: .....

Please include more: .....



# Inspired to make

brings you a wealth of knowledge,  
perfect for any crafters ever  
growing book shelf!

## Mend & Make Fabulous

By Denise Wild

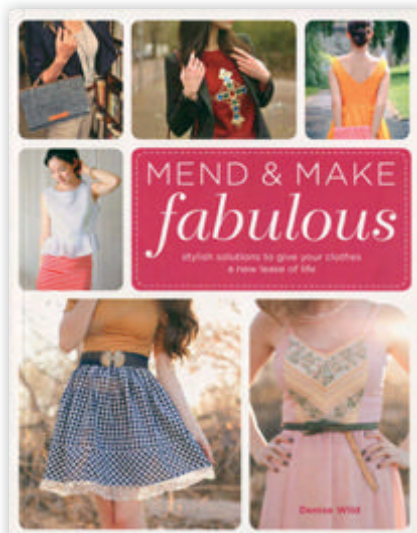

With this book not only will you learn mending basics, including stitching holes, hemming and replacing zips, you will also learn how to add some creativity to your newly found repair skills. It covers solutions for all the most common mending nightmares, includes simple, step-by-step instructions and photographs and is packed with dozens of stylish and inspirational images

The ability to restore clothes is priceless and 'Mend & Make Fabulous' is a comprehensive guide to all the classic mending techniques.

Ref MM

£12.99 + P&P/S&H

## Love ... Sewing

By Cheryl Owen



Traditional needlecrafts are as popular as ever as more and more of us are seeking to 'make do and mend' as a way of saving money. However, making beautiful and original handmade items is a great way to add style and glamour to your home - and can be fun too. Love...Sewing contains a collection of 25 wonderful projects - all of which are really easy to create. Add colour, texture, pattern and comfort to your life with these simple and beautiful projects. Easy to follow instructions with step-by-step photographs make sewing accessible - even for the beginner. All the essential techniques are covered.

Ref LS

£12.99 + P&P/S&H

## Compendium of Sewing Techniques

By Lorna Knight

Covering all the techniques you could ever need, along with handy hints, timesaving tips and homespun secrets, this should be in the library of anyone who enjoys sewing.

In no time, this book will help you:

- \* Improve your sewing skills
- \* Speed up your sewing time
- \* Give your projects a professional finish

Full of easy to follow techniques, which are all organised in the order you'll need them (or you can use the helpful index to dip in and out for help with a specific problem.

There are lots of 'Try it' and 'Fix it' panels throughout the book that have pithy gems of advice, troubleshooting ideas and inspirational ideas.

Ref CST1

£12.99 + P&P/S&H



## The Bag Making Bible

By Lisa Lam

Introduces, explains and demonstrates the myriad materials, hardware, tools and techniques available to the modern crafter, including using the sewing machine. Each fully illustrated chapter ends with a unique, step-by-step project that builds the ultimate handbag wardrobe, with tips for customisation. Full size patterns on a separate pull-out section allow readers to get started right away – no photocopying or enlarging required.

Ref BMB

£15.99 + P&P/S&H



## Delight in the Details

40+ techniques for charming embellishments and accents

By Lisa M. Pace

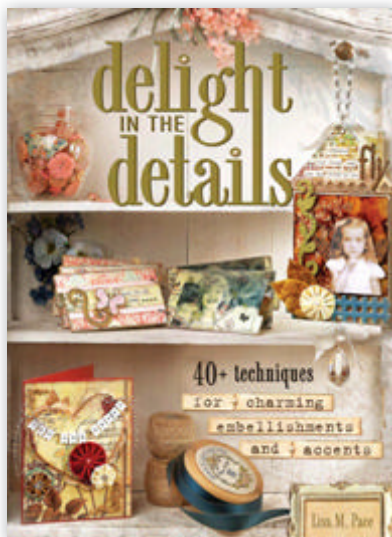

Delight in the Details will inspire you with more than 40 techniques for creating accents and embellishments that will provide a finishing touch to any papercraft project. Get creative with a variety of materials, from simple paper and fabric scraps to glitter, ink, modelling paste and vintage finds. 100 lovely projects – including greetings cards, scrapbook layouts, mini albums and home décor – showcase the techniques in fabulous form. Plus, take a peak inside the author's studio where pretty vintage details come to life. Learn how to create delightful details like:

- Shimmering wire sprays
- Texture paste designs
- Distressed letters
- Crepe paper rosettes
- Delicate felt blooms
- Button bouquets
- Vintage paper leaves

Ref DID

£16.99 + P&P/S&H

## Sewing Alterations & Repairs 200 Questions Answered

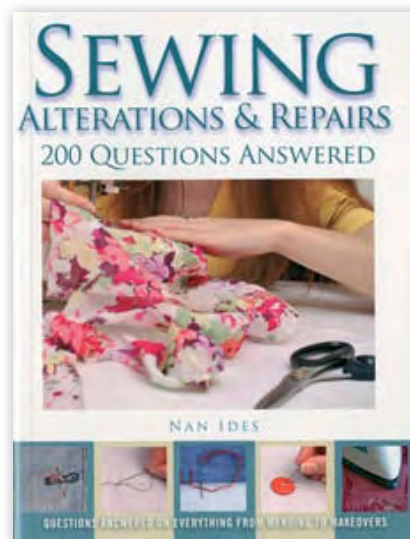

Got an alterations problem you can't solve? Curious to know more about a specific technique? Want to know how to repair both by hand and using a sewing machine? Alterations and Repairs 200 Q&A will come to your rescue, answering 200 questions on a vast range of alteration topics. Straightforward question-and-answer format. How to revamp clothes – including simple ways to alter a garment's style; adding finishing touches; adjusting the size of clothes. Learn all-important mending techniques – including sewing on buttons; re-stitching unravelled sewing; fixing holes and tears; darning woollens; replacing worn or stained cloth.

Ref SAQA

£9.99 + P&P/S&H

To order or to see the full range of inspirational books available visit [shop.inspiredtomake.com](http://shop.inspiredtomake.com) or phone our friendly customer service team on 01684 588599

# Web directory

 Indicates retailers who stock SW

 [www.bredons.co.uk](http://www.bredons.co.uk)  
 **01823 272450**  
BREDON'S SEWING MACHINE CENTRE

[www.sewdevine.co.uk](http://www.sewdevine.co.uk)  
 **JANOME brother SINGER baby lock elna X-Instar TOYOTA Horn**  
Big SAVINGS  
FREE Delivery  
Tel: (0118) 926 8664 • [www.sewdevine.co.uk](http://www.sewdevine.co.uk) • Haberdashery & Spares

[www.sewingmachine-sales.co.uk](http://www.sewingmachine-sales.co.uk)  
24 hour online shopping. **FREE** delivery • Brother, Janome, Pfaff, Elna, Singer.  
Sales, Parts & haberdashery  

 [www.stonefabrics.co.uk](http://www.stonefabrics.co.uk)  
Specialist dress fabrics • Sewing surgery for advice • Same day mail order service  
Tel: 01803 868608  
*Stone Fabrics and Sewing Surgery*

*The Little House of Patchwork*  
Patchwork and Quilting Classes  
Fabric and Quilting Supplies  
07870 559912  
07870 559912  
[www.thelittlehouseofpatchwork.co.uk](http://www.thelittlehouseofpatchwork.co.uk)

[www.beckfordsilk.co.uk](http://www.beckfordsilk.co.uk)  
SILKS & VELVET AT WHOLESALE PRICES, DYED TO SHADE AND PRINTED TO ORDER  
  
Tel: 01386 881507  
Email: [sales@beckfordsilk.co.uk](mailto:sales@beckfordsilk.co.uk)

[sewbox.co.uk](http://sewbox.co.uk)<sup>TM</sup>  
The home of stylish sewing patterns, beautiful fabrics, and convenient all-in-one pattern packs

 01442 245383  
[contact@needlecraftstore.co.uk](mailto:contact@needlecraftstore.co.uk)   
[www.needlecraftstore.co.uk](http://www.needlecraftstore.co.uk)

**sew essential** [www.sewessential.co.uk](http://www.sewessential.co.uk)  
the UK's no. 1 online sewing store  
with over 20,000 products  
  
Husqvarna brother JANOME burda Simplicity elna FISKARS

[www.janome.com](http://www.janome.com)  
**JANOME**  
0161 666 6011

[www.sewdirect.com](http://www.sewdirect.com)  
for sewing accessories, haberdashery &  
Butterick, Kwik Sew, McCall's & Vogue® Patterns

[www.amann-mettler.com](http://www.amann-mettler.com)  
DISCOVER MORE!  
[www.amann-mettler.com](http://www.amann-mettler.com)  
  
Thread.Colour.Imagination.

Family Run Business Since 1952  
**Couling** *STRETCH Your Creativity*  
Sewing Machines Lincoln (01522) 521841  
Lincolnshire  
[www.coulingsewingmachines.co.uk](http://www.coulingsewingmachines.co.uk)  

**Dowlings Sewing Machines**  
Machines and accessories  
for Home, Education and Industry  
Tel: +44 (0) 1268 570248 Email: [sales@dowlings-sew.co.uk](mailto:sales@dowlings-sew.co.uk)  
[www.dowlings-sew.co.uk](http://www.dowlings-sew.co.uk)  

[www.singermachines.co.uk](http://www.singermachines.co.uk)  
24 HOUR ONLINE SHOPPING  
• FREE DELIVERY. SALES,  
PARTS & HABERDASHERY  
Singer Sewing Shop  
**SINGER**  
THE WORLD NUMBER ONE IN SEWING

[www.craftstamper.com](http://www.craftstamper.com)  
*Craft* **stamper** THE UK'S NO 1 MAGAZINE  
FOR STAMPING  
ENTHUSIASTS

[www.sewingworldmagazine.com](http://www.sewingworldmagazine.com)  
**sewing** WORLD  
The first choice for  
machine sewing  
[www.sewingworldmagazine.com](http://www.sewingworldmagazine.com)

Bonus projects, tips and  
special web exclusives for  
the quilter  
  
[www.pandqmagazine.com](http://www.pandqmagazine.com)

ADVERTISE YOUR WEBSITE FOR ONLY £30 + VAT

Call Michelle on **01684 588534** or email [michelle.lazenby@traplet.com](mailto:michelle.lazenby@traplet.com)

# Reader's shop guide

 Indicates retailers who stock SW



## DEVON

### Go Create

Tel. 01297 624246

30 Queen Street, Seaton, Devon.  
EX12 2RB

info@imaginedesigncreate.co.uk

www.imaginedesigncreate.co.uk

Open: 9.30-4.30pm Mon-Sat

Workshops and Classes

Accept major credit cards



## HAMPSHIRE

### Sew Busy

Tel. 01252 444220

Unit B, Brankstone Chambers,  
Branksomewood Road, Fleet,  
Hampshire. GU51 1DW

info@sew-busy.co.uk

www.sew-busy.co.uk



## HEREFORDSHIRE

### Badder Fabrics & Haberdashery

Tel. 01432 379137

36a Aubrey Street, Hereford. HR4 0BU

Email: badderfabrics@hotmail.co.uk

Open: 9.30am-5.30pm Mon-Sat,  
closed on Sunday

Stockist of Husqvarna sewing machines

Major credit cards accepted



## HERTFORDSHIRE

### Craft Corner Ltd

Tel. 01763 268686

Philimore Garden Centre, Cambridge Rd.,

Melbourn, Herts. SG8 6EY

Email: craftcorner@hotmail.co.uk

www.craftcornerltd.co.uk

Open: Mon-Sat 9am-5pm

Sunday 10am-4pm

Janome Sewing Machines now available



### Fashion 'n' Fabrics

Tel. 01727 865038

24 Beech Road, St Albans. AL3 5AS

Fabrics & patterns for dressmaking,

American fabrics for patchwork,

haberdashery & much more



## NOTTINGHAMSHIRE

### Button Moon

Tel. 07958 966628

2 Worrall Avenue, Arnold, Nottingham.  
NG5 7GP

buttonmoon@gmail.com

9am-5pm Mon-Sat

Workshops and Classes



## SUFFOLK

### Beccles Sewing & Handicraft

Tel. 01502 441638

15a Blyburgate, Beccles, Suffolk.  
NR34 9TB

info@becclessewingandhandicraft.co.uk

www.becclessewingandhandicraft.co.uk

9am-5pm Mon, Tues, Thurs.

9am-3pm Weds and 9am-4pm Sat

Major credit cards accepted



## WEST MIDLANDS

### Windsor Crafts

Tel. 01902 340053

14 Springhill Lane, Penn,

Wolverhampton. WV4 4SH

Open Mon-Sat 10.00am-4.30pm

Items stocked: 100% cotton fabrics,

knitting wool and patterns, crochet

yarns and patterns, beads,

buttons, braids, ribbons, waddings,

haberdashery, cross stitch kits, books

and more



### Bead & Button Bazaar

Earlswood Lakes Craft Centre,

Earlswood. B94 5JH.

Tel: 01564 703441

www.beadsandbuttonbazaar.com

Tues-Sun 10.30am-4.30pm

Workshops available

Credit Cards accepted



## WEST MIDLANDS

### Ellie B Jewels

Digbeth Court Business Centre, Suite 5,  
164 High Street, Digbeth, Birmingham.  
B12 0LD Tel: 07869 212345

www.elliebjewels.com

www.facebook.com/elliebjewels

Tues-Sat 10.30am-8.00pm

(mainly for workshops)

I offer various sewing/dressmaking  
workshops/classes to suit all levels.

And classes for children

Accept credit and debit cards plus Paypal



## YORKSHIRE

### Oh Sew Sweet Shop

Tel. 01226 386863

6-7 Fountain Parade, Mapplewell,  
Barnsley. S75 6FW

hello@ohsewsweetshop.co.uk

Open Mon 12.30pm-5pm, Tues

9.15am-5pm, Weds 9.15am-5pm, Thurs

9.15-9pm, Fri 9.15am-5pm, Sat

9.15am-5pm, Sun open if we have a class

Classes and workshops



### Duttons For Buttons

est. 1956

Tel. 01423 502092

For mail order: Duttons for Buttons, Oxford  
St., Harrogate. HG1 1QE.

Over 12,000 button designs!

We offer haberdashery, ribbons, trimmings,

needlecrafts and lots more

michelle@duttonsforbuttons.co.uk

www.duttonsforbuttons.co.uk

follow us on Facebook

Personal shoppers welcome in Harrogate,

York and Ilkley



## SCOTLAND, CENTRAL

### Pembertons Sewing & Craft Centre

Tel. 01786 462993

21-25 Friars St., Stirling. FK8 1HA

Scotland's Premier Sewing Centre

Sales & Repairs for all leading makes of

Sewing & Overlocking Machines, Presses

& Cabinets. Needlecrafts, Haberdashery,

Dress & Craft Fabrics, Wool & Patterns.

Shop online at www.psmc.co.uk

Advertise your shop here at just £15 + vat  
contact Michelle today. Phone: 01684 588534  
or email: michelle.lazenby@traplet.com

To become a stockist call Angela on 01684 588568  
or email [angela.price@traplet.com](mailto:angela.price@traplet.com)

# Reader's market

Send your advertisements to: Sewing World, Traplet House, Willow End Park, Blackmore Park Road, Malvern, Worcs. WR13 6NN, England. We will print your classified advertisements in the next available issue of Sewing World. Classified adverts received after copy date may be held over for the following issue. No responsibility will be accepted for misprints. **Trade Description Act:** Attention should be paid to the requirements of the Act when giving detailed descriptions of all goods offered for sale. **The Business Advertisements (Disclosures) Order 1977** requires that persons attempting to sell goods in the course of business must make that fact clear. Consumers should know whether an advert relates to a sale by a trader or private seller.

## FREE CLASSIFIEDS ♦ FREE CLASSIFIEDS ♦ FREE CLASSIFIEDS ♦ FREE CLASSIFIEDS ♦ FREE CLASSIFIEDS

**JANOME** Memorycraft 6600P professional computerised sewing machine, 5 years old, instruction manual, recently serviced, standard accessories, excellent condition, £485, buyer collects. 01634 200412, Kent.

**BERNINA** stitch regulator, boxed and never used, £250, for use with Series 5 machines and upwards. Bernina Virtuosa 153 Quilters Edition, includes 1/4" quilting foot, as new, buyer collects, £475 ono, selling to upgrade. 01752 930631, Devon.

**BROTHER** Super Galaxy sewing/embroidery machine, excellent condition, £600. Brother 260, chunky knitting machine, ribber and intarsia carriage manuals, £400. Garter carriage KG88 with rails, £100. Hague linker, manuals, £75. Knitting machine cabinet, £50, buyer collects. 07949 811052, Surrey.

**JANOME** Memorycraft Horizon sewing/embroidery machine, 12000, approx. 2 years old and just serviced, loads of feet, stitches and embroidery patterns, 4 hoops, many accessories and large surface extension table, will deliver within 40 miles or send by carriage, Devon, £2,900 ono. lesley.littleowl@gmail.com

**JANOME** Memorycraft 5900QC computerised sewing machine for sale, 534 stitch options, including alphabets, 10 auto 1 step buttonholes, 3 fonts, pattern elongation, variable stitch length and width, automatic tension control, memorise stitch and alphabet combinations, last stitch recall, auto needle threader, programmable needle up/down button, start/stop button, twin needle regulator. Very easy to use, complete with large extension table, hard cover, extra feet and bobbins, little used, £650. Cornwall area. Contact: anniemacdonald1@btinternet.com

**BERNINA** 1130 computerised sewing machine, very good condition, carry case, foot control, sewing table, presser foot lifter, accessories, manuals, bought new 1986, £450 cash ono, buyer collect. 01923 710190, Herts.

**JUKI** HZL-F Series: 3 years old, hardly used, £600 ono. 01243 375506, Hants.

**JANOME** Digitiser Junior Version 4, £100 ono. Upgrade is reason for sale. 01873 853016, Monmouthshire.

**JANOME** snap-on feet, piping foot, zig-zag foot, 1/4" seam, patchwork foot, concealed zip foot, with instructions, £80, buyer collects or I will post for cost. 01948 663853, Shropshire.

**HUSQVARNA** accessories, 120 x 120 hoop for Designer SE Diamond, £29. 260 x 200 hoop Designer Diamond, £39. Designer 224 thread velvet, 245 cutwork techniques, 228 decorative edge Designer SE Diamond, 212 majestic cutwork Diamond only, £35 each, p&p £1.75. 01225 312463, Bath.

**BOOKS** for sale, Bags of Style, 25 patterns, Bags, Bags, Bags, 18 patterns, 20 floral bags to make, embroidery bags, quilt bag, totes to make, all £5 each + postage. Handmade embroidered bags, all in perfect condition. 01772 735985, Lancs.

**BERNINA** feet No 3C buttonhole foot, £30. No 26 Teardrop embroidery foot, £10. No 43 couching foot, still in wrapper, £15. 01942 581593, Lancs.

**TONY** blindstitch hemming machine, Model CM500, only used a few times, have no further use for it, a must for anyone who makes curtains as it gets rid of the need for any hand sewing of hems, etc., offers around £300 plus carriage, anyone with questions please call 01302 727130, S. Yorks.

**HORN** Eclipse sewing cabinet, light oak, immaculate condition, insert for Brother Innov-Is 350 included, purchase of larger sewing machine forces reluctant sale, £600, buyer collect or arrange carriage. Contact Chris 01278 457139 or email: p.galley@talktalk.net Somerset.

**BERNINA** 820, just over two years old, BSR foot and many extras, £1,000. Please call Miriam 01530 273786, Midlands.

**BROTHER** embroidery cards for asle, for sale. Wanted Brother embroidery cards numbers 43, 51, 78 and 79 please. Wanted, I am looking for an old fashioned wire dressmaking dummy with the stand please. Also wanted Simplicity bias binding and piping machine. If you can help with with any of these please call 0208 354 4434.

## ADVERTISE FREE IN OUR SEWING TITLES

PRIVATE FOR SALE/WANTED CLASSIFIED ONLY



Use this coupon for FREE private classified ads. Free ads are ONLY accepted on a coupon, by post, fax or email. TICK WHICH MAGAZINE/S YOU WISH TO ADVERTISE IN

1	2	3	4	5
6	7	8	9	10
11	12	13	14	15
16	17	18	19	20
21	22	23	24	25
26	27	28	29	30

**ANY INFORMATION GIVEN BELOW WILL NOT APPEAR IN YOUR ADVERT.**

PLEASE ENSURE YOUR NAME AND ADDRESS IS INCLUDED FOR RECORD PURPOSES.

Name .....

Address .....

.....County .....

Postcode ..... Telephone Number .....

Send to: Sewing World Magazine, Traplet Publications Ltd., Traplet House, Willow End Park, Blackmore Park Road, Malvern, Worcestershire, WR13 6NN, UK.

**Fax or E-mail us now!**

Fax no. +44 (0)1684 578558 Email: adcopy@traplet.com

**IF YOU DON'T WANT TO SPOIL YOUR MAGAZINE JUST PHOTOCOPY THIS FORM.**

We will print your classified advertisement in the next available issue of Sewing World Magazine. Classified adverts received after the copy date may be held over for the following issue. We advise you to print clearly (capital letters) the text of your advert and indicate, which section you would like your advert to appear in. No responsibility will be accepted for misprints or printing errors.

If you do not wish to receive future mail shots please tick this box

## Advertisers Index

Amann Mettler	21	New Forest Fabrics	55	The Festival Of Quilts 2015	81
Bernina	20	Pennine Outdoor	65	The Sew Studio	55
Brother	14	Plush Addict	55	TPL Back Issues	69
Colehill Accessories	77	Presencia	21	TPL Binders	65
David Drummond	9	Regenovex	2	TPL Books	92
Frank Nutt Sewing Machines	43	Sew Box	55	TPL Digital	69
Horn Furniture	99	Sew2Go	65	TPL Products	86-87
Janome	100	Sew Devine	35	Web Directory	94
Justhandson.tv	49	Singer Machines	65		
Leons	69	Subscriptions	30-31		



# Coming next month...

www.sewingworldmagazine.com

# sewing

WORLD

July 2015 issue 233



Plus - Lots more lovely sewing projects for you and your home

**ON SALE MONDAY 15TH JUNE 2015**

# The Final Thread

Reproduction is big business in the sewing world, whether it's the big companies rereleasing original 50s and 60s patterns – tweaked for modern day sizing, or fabric companies re-issuing designer collections that fans missed out on first time around. It all adds up to big bucks for the companies involved. I have mixed feelings about re-issues. Don't get me wrong, I am a diehard fan of all things vintage. I scour charity shops and car boots sales for original 70s sewing patterns (my favourite era) plus any scraps of fabric I might be lucky enough to find. But I also appreciate innovation and re-issues and repros are the antithesis of that. Happily, I have noticed some companies and individuals in the sewing world who are happy to try something new.

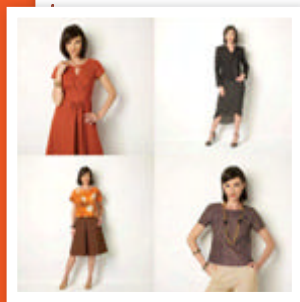

I am a big fan of Liesl Gibson. She has developed a number of home sewing brands including Oliver + S – which transformed children's clothing patterns, Liesl + Co – downloadable PDF patterns for everyday wear and Lisette patterns – first produced in collaboration with Simplicity and now part of the Butterick brand. Butterick liked her new B6168 fit-and-flare dress with

its pleated wrap bodice design so much, that they made it the cover star for their Spring/Summer 2015 catalogue cover. I confess I bought this pattern immediately upon release and had to wait for more stock to arrive; it is a very popular design. Lisette patterns are widely available via Butterick pattern stockists.

Fit-and-flare dresses are always a popular choice but Liesl goes beyond that shape with her other Lisette designs. The four patterns offer a core wardrobe collection of separates and key pieces to mix and match and suit women of different ages, sizes and proportions. The Moto jacket (pattern B6169) looks like another winning design – its princess seams make for easier bust adjustments and the style is currently a popular choice for home sewists with a version having featured on the Great British Sewing Bee a few months back. In Liesl Gibson's collaboration with Butterick, the two worlds of a big sewing pattern company and the independent designer combine and we get the best of both with a reasonably priced and readily available paper pattern, alongside extras on the Lisette blog like sew-alongs and style and fabric inspiration advice – [www.sewlisette.com/blog](http://www.sewlisette.com/blog).

Finnish clothing pattern label Named Clothing [www.namedclothing.com](http://www.namedclothing.com) has had an innovative approach from its first collection in 2013. Aimed at a relatively young demographic but not exclusively so, their Scandinavian aesthetic is sleek, minimal and has a fashion focus comparable to ready-to-wear clothing. Over the last couple of years they have released four seasonal collections, each bigger than the one before and each accompanied by beautifully photographed lookbooks. Their latest collection 'Ticket' was inspired by travel and tourism and is a mix of sporty and feminine elements. My favourite styles are the

Lourdes Cropped jacket which features an inverted back pleat and the Augusta Hoodie with its neat welt pockets and baseball aesthetic. I don't even pretend to like every pattern they produce – some shapes are a long way from anything I would ever wear and I would like to see a little more diversity in their model choice, but, I love their approach. The stunning photography, well drafted designs and the fact they have taken on customer feedback – are expanding their size range in some styles from UK size 4 to 22. Patterns are available as PDFs via [www.namedclothing.com](http://www.namedclothing.com) and printed pattern stockists include [www.backstitch.co.uk](http://www.backstitch.co.uk).

If children's clothing is more your sewing bag, take a look at Figgy's [www.figgys.myshopify.com](http://www.figgys.myshopify.com). I look longingly at their gorgeous designs and wish they were available in adult sizes too. They have an effortless casual chic, no frills, no fuss, combined with the practicality and ease of movement that children need in their clothing. Many of the items are knit/jersey fabrics and the fastenings are minimal. They are styles that don't look handmade, more like the models have stepped out of Boden or Gap catalogues. Shelly Figueroa, founder of the Figgy's brand, sells her patterns as PDF downloads on her website and printed paper patterns are stocked at independent sewing shops. There are designs for girls and boys and from 18 months to 8/9yrs. You can also find her Zephyr Romper design as a Craftsy class with the pattern included alongside a wealth of advice on fitting and adapting the pattern to create new styles. [www.craftsy.com/class/kids-romper-revamp-creative-pattern-adapting/100](http://www.craftsy.com/class/kids-romper-revamp-creative-pattern-adapting/100).

Finally, if you cannot find the textile design you are looking for at your local fabric shop, Woven Monkey offers you the chance to create your own custom printed fabric [www.wovenmonkey.com](http://www.wovenmonkey.com). You create your design digitally (there is help on hand with an extensive FAQ section), decide your layout and preview your design as you make changes. The turnaround time in the UK is only 5-10 days and the minimum amount of fabric you can have printed is a 20cm test square. At £21.99 per metre upwards it is not a budget option, but all base fabrics offered are wide. They also offer a fabric design gallery to choose from if your design muse has deserted you.

I like a little vintage inspiration but I love to look forwards and find innovation, especially for the younger sewists encouraged by the growth of sewing in recent years. Onwards and upwards!

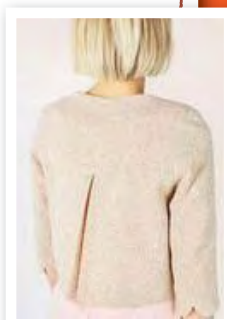

Photography: Jenni Holma, model: Inara/Modelboom, hair & make-up: Tina Toratti/Lumo Beauty



Kerry Green is co-author of 500 Quilt Blocks and has contributed to a range of quilting books and magazines. You can find more sewing tips, free patterns, tutorials and more at Kerry's blog: [verykerryberry@blogspot.co.uk](mailto:verykerryberry@blogspot.co.uk)

# The Horn Gemini

The small sewing cabinet with big ideas!



[www.hornfurniture.co.uk](http://www.hornfurniture.co.uk)

Can't get to see the one you'd like?  
Come see our range at an exhibition.  
Visit us at  
[www.hornfurniture.co.uk/events/](http://www.hornfurniture.co.uk/events/)  
to find out where we are next.....



Set your sewing machine up in seconds....

.... No need to lift, carry or struggle to find where to use your sewing machine again!

Possibly the best scissors you'll ever get to use!

Ask us about our new range of precision made German scissors..... a perfect companion for your new cabinet.



7 large lockable smooth running castors; so its easy to move around and well supported whilst its being used.

Fitted with our easy push down release air-lifter system. With just a simple push down it will lift your sewing machine into either a flatbed or to a free- arm position making it ready to be used in a matter of seconds. Even with its compact dimensions this cabinet is still capable of fitting virtually all sewing machines except for a few of the very largest ones on the market today. (For these larger machines you will need one of our cabinets fitted with a 'maxi' air-lifter. If you have any doubts, please contact us to find out more information on fitting your particular brand and model of sewing machine)

Fantastically compact—only 2½' by 1½' when its closed

A flatbed insert custom cut to fit your sewing machine- **included**

Fitted with a convenient lift up back working area which is ideal for supporting heavier, larger projects helping to eliminate 'needle dag'.

Handy storage areas including 2 removable storage accessory boxes. Extra storage can be added by purchasing the Horn 'Rolla Storage' unit

Finished in 3 attractive, durable finishes available from stock.

Delivered fully assembled by our **own** delivery vehicles.

For more information Download our latest brochure now from;  
[www.hornfurniture.co.uk](http://www.hornfurniture.co.uk)

Order yours now from your nearest Horn specialist listed below or contact us on 01793 834304 for more information

<p><b>Beds</b> Tudor Rose, Patchwork, Oakley, 01234 824983 <a href="http://www.tudorrosepatchwork.co.uk">www.tudorrosepatchwork.co.uk</a></p>	<p><b>Essex</b> Superstitch, Leigh on Sea 01702 478830 <a href="http://www.superstitch.co.uk">www.superstitch.co.uk</a></p>	<p>Sewfine Sew/Machines, Watford 01923 693734 <a href="http://www.sewfine.co.uk">www.sewfine.co.uk</a></p>	<p>The Sew/Knit Centre, Southport, 01704 534688</p>	<p>Husqvarna Studio, Bath 01225 482413 <a href="http://www.husqvarnastudiobath.co.uk">www.husqvarnastudiobath.co.uk</a></p>	<p>L. M Nutt Sew/Machines, Sutton Coldfield 0121 373 5497 <a href="http://www.nuttsewingshop.co.uk">www.nuttsewingshop.co.uk</a></p>
<p><b>Berks</b> Sew Devine, Reading 0118 926 8664 <a href="http://www.sewdevine.co.uk">www.sewdevine.co.uk</a></p>	<p>Dowlings Sew/mach, Wickford 01268 562022 <a href="http://www.dowling-sew.co.uk">www.dowling-sew.co.uk</a></p>	<p><b>Kent</b> The World of Sewing, Pratts Bottom 01689 538638 <a href="http://www.worldofsewing.com">www.worldofsewing.com</a></p>	<p><b>Lincs</b> Couling Sew/Machines, Lincoln 01522 521841 <a href="http://www.coulingsewingmachines.co.uk">www.coulingsewingmachines.co.uk</a></p>	<p><b>Suffolk</b> Sew creative, Bury St. Edmunds 01284 755459 <a href="http://www.sewcreative.co.uk">www.sewcreative.co.uk</a></p>	<p><b>Wilts</b> Cloth of Gold, Wootton Bassett 01793 853908</p>
<p>Sewmaster Sew/Machines, Reading 0118 957 1845 <a href="http://www.sewmaster.co.uk">www.sewmaster.co.uk</a></p>	<p><b>Greater London</b> Sew-works, Ewell, 0208 393 8488 <a href="http://www.sewworks.co.uk">www.sewworks.co.uk</a></p>	<p>CCB Sew/ Machines, Rochester, 01634 841597 <a href="http://www.ccbsewing.co.uk">www.ccbsewing.co.uk</a></p>	<p><b>Norfolk</b> Sew Creative, Norwich 01603 305888 <a href="http://www.sewcreative.co.uk">www.sewcreative.co.uk</a></p>	<p><b>Surrey</b> The World of Sewing, Croydon 0208 681 1811 <a href="http://www.worldofsewing.com">www.worldofsewing.com</a></p>	<p><b>Worcs</b> Creative Hands 2, Worcester 01905 24940 <a href="http://www.creativehands2.co.uk">www.creativehands2.co.uk</a></p>
<p><b>Bristol</b> Direct Sew/Machines, Bristol 0117 977 8216 <a href="http://www.direct-sewingmachines.co.uk">www.direct-sewingmachines.co.uk</a></p>	<p>Lewisham &amp; Deptford Sew/Mach 0208 6921077 <a href="http://www.sewingmachinesuk.co.uk">www.sewingmachinesuk.co.uk</a></p>	<p>Maidstone Sewing Centre, Maidstone 01622 670254 <a href="http://www.sewingmachinesuk.co.uk">www.sewingmachinesuk.co.uk</a></p>	<p>Sew/Mach World, Kings Lynn 01553 773362 <a href="http://www.sewingmachineworldonline.co.uk">www.sewingmachineworldonline.co.uk</a></p>	<p><b>Tyne &amp; Wear</b> Tullys, Sunderland 0191 565 7995 <a href="http://www.tullyssewingmachines.co.uk">www.tullyssewingmachines.co.uk</a></p>	<p><b>Yorks</b> Whiterose Sew/Craft Centre Harrogate 01423 503767 <a href="http://www.whiterosesewing.co.uk">www.whiterosesewing.co.uk</a></p>
<p><b>Cambs</b> Sewcreative, Cambridge 01223 350691 <a href="http://www.sewcreative.co.uk">www.sewcreative.co.uk</a></p>	<p>Regent Sew/Machines, Ilford 0208 478 0669 <a href="http://www.homeofsewing.co.uk">www.homeofsewing.co.uk</a></p>	<p>Ashford Sew/Knit Centre, Ashford, 01223 620948 <a href="http://www.sewingcentres.com">www.sewingcentres.com</a></p>	<p><b>Northants</b> Sew-Northampton, Northampton 01604 637200 <a href="http://www.sewing-centres.co.uk">www.sewing-centres.co.uk</a></p>	<p>The Fat Quarters, Newcastle 01207 565728 01207 565728</p>	<p>Flynns Sew/centre, At Browns of York, 01904 561234 <a href="http://www.flynns-york.co.uk">www.flynns-york.co.uk</a></p>
<p><b>Cheshire</b> Jaycotts, Chester 01244 394099 <a href="http://www.jaycotts.co.uk">www.jaycotts.co.uk</a></p>	<p>Wimbleton Sew/Machines, Wimbledon 0208 542 5240 <a href="http://www.wimsewretail.co.uk">www.wimsewretail.co.uk</a></p>	<p>The World of Sewing, Tunbridge Wells 01892 533188 <a href="http://www.worldofsewing.com">www.worldofsewing.com</a></p>	<p><b>Notts</b> Coles Sewing Centre Ltd., Nottingham 0115 988 1550 <a href="http://www.colessewingcentre.co.uk">www.colessewingcentre.co.uk</a></p>	<p>Singer Sewing Centre, Beeston, 0115 922 3904 <a href="http://www.singershop.co.uk">www.singershop.co.uk</a></p>	<p>Helens Houses, Doncaster 01302 708227 <a href="http://www.helenshouses.co.uk">www.helenshouses.co.uk</a></p>
<p><b>Cornwall</b> Direct Sew/ Machines, Redruth, 01209 216942 <a href="http://www.thesewingstudio.co.uk">www.thesewingstudio.co.uk</a></p>	<p><b>Greater Manchester</b> Bambers Sew/Machines, Manchester 0161 707 7786 <a href="http://www.bambersew.com">www.bambersew.com</a></p>	<p>Welling Sew/Machines, Welling 0208 304 0470</p>	<p><b>Oxon</b> GTS Sew/Mach, Banbury 01295 701384 <a href="http://www.gtsssewingmachines.co.uk">www.gtsssewingmachines.co.uk</a></p>	<p>The Sewing Centre, Shrewsbury 01743 343902 <a href="http://www.sewingmachineshropshire.co.uk">www.sewingmachineshropshire.co.uk</a></p>	<p>M.K.C. Sew/Mach, Leeds 0113 245 3156 <a href="http://www.mkcservice.co.uk">www.mkcservice.co.uk</a></p>
<p><b>Devon</b> Exeter Sew/Machines, Exeter 01392 275660 <a href="http://www.exetersewing.co.uk">www.exetersewing.co.uk</a></p>	<p><b>Glos</b> Westend Sew/Centre, Cheltenham 01242 244025 <a href="http://www.westendsewing.co.uk">www.westendsewing.co.uk</a></p>	<p><b>Lancs</b> Dalby &amp; Jones Ltd., Preston, 01772 254558 <a href="http://www.sewingmachinespreston.co.uk">www.sewingmachinespreston.co.uk</a></p>	<p><b>Shrops</b> Sewing Centre, Shrewsbury 01743 343902 <a href="http://www.sewingmachineshropshire.co.uk">www.sewingmachineshropshire.co.uk</a></p>	<p>Singer Machines Ltd, Whitley Bay 0191 252 5825 <a href="http://www.sewingmachine-sales.co.uk">www.sewingmachine-sales.co.uk</a></p>	<p><b>Scotland</b> David Drummond, Edinburgh 0131 539 7766</p>
<p><b>Dorset</b> Hansons Fabrics, Sturminster Newton 01258 472698 <a href="http://www.hansonsfabrics.co.uk">www.hansonsfabrics.co.uk</a></p>	<p><b>Hants</b> Hampshire Sewing Machines, Fareham 01329 280499 <a href="http://www.hampshiresewingmachines.com">www.hampshiresewingmachines.com</a></p>	<p>Etty-Lilly, Bolton le Sands, 01524 734713 <a href="http://www.etty-lilly.co.uk">www.etty-lilly.co.uk</a></p>	<p><b>Somerset</b> Bredons Sew/Machines, Taunton 01823 272450 <a href="http://www.bredons.co.uk">www.bredons.co.uk</a></p>	<p>D.C.Nutt Sew/Machines, Bloxwich 01922 497603 <a href="http://www.dcnuttsewingmachines.co.uk">www.dcnuttsewingmachines.co.uk</a></p>	<p>Pemberton's Sew &amp; Craft Centre, Stirling 01786 462993 <a href="http://www.psmc.co.uk">www.psmc.co.uk</a></p>
	<p><b>Herts</b> Rona Sewing Machines, Waltham X 01992 640250 <a href="http://www.onlinesewingmachines.co.uk">www.onlinesewingmachines.co.uk</a></p>	<p>Lords at Oswaldtwistle Mills, 01254 389171 <a href="http://www.lordsewing.co.uk">www.lordsewing.co.uk</a></p>		<p>Frank Nutt Sew/Machines, Kings Heath 0121 444 3978 <a href="http://www.franknutt.co.uk">www.franknutt.co.uk</a></p>	<p><b>Wales</b> Newport Sew/Centre, Newport 01633 284646 <a href="http://www.jbsewing.com">www.jbsewing.com</a></p>

Retailers marked to the right with a are Horn Superstores holding 3 or more current cabinets on display and a has 6 or more on display

(The sewing machine and accessories are not included)

# Sewing with STYLE

DAZZLING  
OFFERS FROM  
**£99**

## MODEL 2015s

- 14 Stitches
- Auto 4-step buttonhole
- Variable stitch length
- Convertible free arm
- Quick change snap on feet



**SPECIAL  
PURCHASE  
£99**

AVON	Direct Sewing Machines, Bristol - 0117 977 8216	NOTTINGHAMSHIRE	Cresswell Sewing Machines, Nottingham - 0115 926 7572
BEDFORDSHIRE	Tudor Rose Patchwork, Oakley, Bedford - 01234 824 983	OXFORDSHIRE	Witney Sewing Machine Centre, Witney - 01993 704535
BERKSHIRE	Sew Devine, Reading - 0118 926 8664		Witney Sew & Knit Centre, Witney - 01993 702 772
BUCKINGHAMSHIRE	Alans Sewing Machines, High Wycombe - 01494 527600	SHROPSHIRE	Sewing Machine Centre, Shrewsbury - 01743 343 902
	Threads and Patches, Milton Keynes - 01908 649687	SOMERSET	Bredons Sewing Machines, Taunton - 01823 272 450
CAMBRIDGESHIRE	Sew Creative, Cambridge - 01223 350 691	SUFFOLK	Sew Creative, Bury St Edmunds - 01284 755459
CHESHIRE	J & P Sewing Machines, Warrington - 01925 633 831	SURREY	C & A Supply Co. Ltd, Cranleigh - 01483 267 777
	Phil Morton Sewing Machines, Macclesfield - 01625 433 131		Redgewells, Worcester Park - 0208 337 3444
CORNWALL	The Sewing Studio, Redruth - 01209 216 942		The Quilt Room, Dorking - 01306 877 307
DERBYSHIRE	Elegance, Derby - 01332 382 292		The World of Sewing, South Croydon - 0208 681 1811
	Ilkeston Sewing & Janome Centre, Ilkeston - 01159 307 664	SUSSEX	Woking Sewing & Knitting Centre, Addlestone - 01932 352 958
	The Knitting & Sewing Bee, Chesterfield - 01246 232 176		Brighton Sewing Centre, Brighton - 01273 621 653
DEVON	Exeter Sewing Machine Company, Exeter - 01392 275 660		Clothkits Ltd, Chichester - 01243 533 180
	Hulu, Modbury - 01548 831 911		Eclectic Maker, Worthing - 0845 862 5552
	Soft Touch Needlecrafts, Tavistock - 01822 617 673		Hastings Sewing Centre, Hastings - 01424 423 108
DORSET	Hansons Fabrics, Sturminster Newton - 01258 472 698		G Tully Sewing Machines, Sunderland - 0191 565 7995
	So N Sews, Weymouth - 01305 766 411	TYNE & WEAR	Sewing Machine Sales, Whitley Bay - 0191 252 5825
DURHAM	UK Sewing Machines, Darlington - 01325 463 630	WARWICKSHIRE	Leamington Spa Sewing Machines, Leamington Spa - 01926 338 749
ESSEX	Superstitch Machine Co, Leigh on Sea - 01702 478830	WILTSHIRE	Cotswold Stitchcraft, Malmesbury - 01666 823 245
GLOUCESTERSHIRE	Cotswold Sewing Machines, Stroud - 01453 763660		West Wilts Sewing Machine Co, Trowbridge - 01225 753 792
	West End Sewing Centre, Cheltenham - 01242 244025	WEST MIDLANDS	Brewers Sewing Machines, Wolverhampton - 01902 458 885
HAMPSHIRE	Eastleigh Sewing Centre, Eastleigh - 02380 650 808		Coventry Sewing Centre, Coventry - 02476 257266
	Hampshire Sewing Machines, Fareham - 01329 280499		D C Nutt Sewing Machines, Walsall - 01922 497 603
	Reads of Winchester, Winchester - 01962 850 950		Frank Nutt, Kings Heath - 0121 444 3978
HEREFORDSHIRE	Badder Fabrics, Hereford - 01432 379 137		GUR Sewing Machines, Birmingham - 0121 359 5335
HERTFORDSHIRE	Chicks Embroidery, Letchworth - 01462 670 007		L & M Nutt, Sutton Coldfield - 0121 373 5497
	Rebecca Woollard Sewing School, Hatfield Heath - 07887 654 717		S Nutt Sewing Machines, Birmingham - 0121 327 2828
	Rona Sewing Machines, Waltham Cross - 01992 640250	WORCESTERSHIRE	Creative Hands 2, Worcester - 01905 24940
	Sewfine Sewing Machines, Watford - 01923 693 734		Inkberrow Design Centre, Redditch - 01527 69100
	Sewing Machine Discount, Borehamwood - 0208 236 1520		Topstitchers, Kidderminster - 01562 822 698
KENT	Ashford Sewing Centre, Ashford - 01233 620948	YORKSHIRE	Arcade Sewing Machines, Huddersfield - 01484 429 808
	Barcham Sewing Centre, Whitstable - 01227 264 271		C & G Sewing Machines, Bradford - 01274 306352
	Maidstone Sewing Centre, Maidstone - 01622 670 254		Electra (DA) Company, Doncaster - 01302 340 369
	The Sewing Shop, Canterbury - 01227 457 723		Flynn's® Browns of York, York - 01904 561234/611166
	The World of Sewing, Pratts Bottom, Orpington - 01689 638 638		Lennox Sewing Machines, Rotherham - 01709 377 797
	The World of Sewing, Tunbridge Wells - 01892 533188		MKC Services, Leeds - 0113 245 3156
LANCASHIRE	Hobkirk Sewing Machines, Blackburn - 01254 693555		Samuel Taylors, Skipton - 01756 700 946
	Hobkirk Sewing Machines, Bury - 0161 764 4450		Sewing Centre, Bridlington - 01262 603057
	Lestan Sewing Machines, Nelson - 01282 614 511	ISLE OF MAN	Sewing Centre, Scarborough - 01723 363 167
	M & S Sewing Machines, Heywood - 01706 366 943	IRELAND	White Rose Sewing Machines, Harrogate - 01423 503767
	S A Sewing Machines, Oldham - 01706 355 529		Woodseats Sewing Machines, Sheffield - 0114 255 2822
	S A Sewing Machines, Rochdale - 01706 355 529		Joan's Woods & Crafts, Onchan - 01624 626 009
	Sew-Knit (Dalby & Jones), Preston - 01772 254 558		Sew N Knit Belfast, Belfast - 0289 045 6015
	Transworld Sewing Machines, Leigh - 01942 608028		Sew N Knit Lisburn, Lisburn - 0289 267 0908
LEICESTERSHIRE	Cresswell Sewing Machines, Leicester - 07979 798 010		Singer Sewing Centre, Ballymena - 0282 564 0034
	The Sewing Café, Hinkley - 01455 698 034	SCOTLAND	David Drummond, Edinburgh - 0131 539 7766
	Couling Sewing Machines, Lincoln - 01522 521841		ESC Sewing Machines, Keith - 01542 887 000
	Seweezy, Gainsborough - 01427 614 570		N.J. Sewing Machine Services, Brightons Falkirk - 01324 711 333
LONDON (GTR)	Lewisham & Deptford Sewing Machines, Deptford - 0208 692 1077		Pemberton's Sewing Machines, Stirling - 01786 462 993
	Redgewells, South West London, 0208 337 3444		Quilt Creations, Inverness - 01463 719 369
	SM Sewing Machines, Neasden - 0208 452 4257		Sew Materialistic, Ayr - 01292 285 801
	The Sewing Centre, Battersea - 0207 228 3022	WALES	Butterfly Fabrics, Cardiff - 02920 470 808
	Wimbledon Sewing Machine Co, South Wimbledon - 0208 542 5240		Calico Kate, Lampeter - 01570 422 866
MANCHESTER (GTR)	Bamber Sewing Machines, Manchester - 0161 707 7786		Cliffords Sewing Machines Ltd, Swansea - 01792 655 928
	R. Bullock & Son Ltd, Wigan - 01942 247 836		J B Sewing Machine Co, Ltd, Newport - 01633 284 646
MERSEYSIDE	Affordable Sewing, Moreton, Wirral - 0151 677 7755		Newport Sewing Centre, Newport - 01633 284 659
	Sewing & Knitting Centre, Southport - 01704 534 688		Quay Street Sewing Centre, Haverfordwest - 01437 762 355
MIDDLESEX	Tyson's Sewing Machines, Hounslow - 0208 570 6790		Sewing Machines Direct, Wrexham - 0800 092 5215
	Tyson's Sewing Machines, Southall - 0208 574 1587		
NORFOLK	Sewing Machine World, Kings Lynn - 01553 773362		
	Sew Creative, Norwich - 01603 305 888		
NORTHAMPTONSHIRE	Sew Northampton, Northampton - 01604 637200		

[www.janome.co.uk](http://www.janome.co.uk)

The 'Sewing with Style' offers are available from Janome sewing machine retail outlets nationwide. Promotion starts **6th April 2015** to **30th May 2015** (All offers subject to stock availability.)

# JANOME

The World's leading sewing machine manufacturer